

NAVARRO COUNTY COMMISSIONER'S COURT

A Special meeting of the Navarro County Commissioner's Court was held on Monday, the 10th, day of April, 2017 at 10:00 a.m., in the Courtroom of the Navarro County Annex Building 601 N. 13th Street in Corsicana, Texas. Presiding Judge HM Davenport, Jr. Commissioners present Jason Grant, Eddie Moore, and James Olsen.

1. 10:01 A.M. Motion to convene by Comm. Olsen sec by Comm. Moore
Carried unanimously
2. Opening prayer by Comm. Grant
3. Pledge of Allegiance
4. Public Comments-Melanie Cagle-introduced new employee in dispatch, Don King-#14, Johnny Wheorley-Mustang VFD, Jackie King-Lesson & Invitation
PG 479

Consent Agenda

- Motion to approve consent agenda items 5-8 by Comm. Olsen sec by Comm. Grant
Carried unanimously
5. Motion to approve and pay bills as submitted by the County Auditor, including Current bills, and payroll (paid 04/13/2017) **TO WIT PG 480-499**
 6. Motion to approve and accept the action of the Navarro SWCD for Richland Creek site 31, Navarro County **TO WIT PG 500-548**
 7. Motion to approve of minutes of the February 2, 2017 Planning and Zoning meeting **TO WIT PG 549-550**
 8. Motion to approve re-plat of Vista Ridge, Phase II, combining lots 128, 129, 130, 131, 132, 133, and 134 for David H. Allen and Claudia Allen

Action Items

9. No action taken on Burn ban remains off
10. Table to approve and declaring as salvage unused and damaged furniture at Ideal Storage

11. Tabled approving Lockridge Priest contract for air conditioning in Courthouse and Annex
12. Motion to approve Tax Collection Report for March 2017, Mike Dowd by Comm. Grant sec by Comm. Moore **TO WIT PG 551-556**
Carried unanimously
13. Motion to approve posting of closing 1945 feet of SW CR 3030 in Precinct 4 by Comm. Olsen sec by Comm. Grant
Carried unanimously
14. No action to accept Cities Agreement to provide Ambulance Service to Navarro County
15. Motion to approve declaring the listed Sheriff's Vehicles as surplus a 2001 Chevy Tahoe Unit # 2106 Vin # 1GNEK13T41R124868 by Comm. Grant sec by Comm. Olsen
Carried unanimously
16. Motion to approve declaring Tactical Team weapons as a surplus by Comm. Moore sec by Comm. Grant
Carried unanimously
17. Motion to approve the purchase of a Insinger Tray washer system for Jail kitchen by Comm. Olsen sec by Comm. Moore **TO WIT PG 557-564**
Carried unanimously
18. Motion to approve proposal for repairs to the Navarro County Courthouse by Comm. Grant sec by Comm. Olsen **TO WIT PG 565-566**
Carried unanimously
19. 10:32 A. M. Motion to go into Executive Session Pursuant to the Texas Government Code Section 551.074 to discuss Personnel by Comm. Olsen sec by Comm. Moore
Carried unanimously

Motion to come out of Executive Session Pursuant to the Texas Government Code Section 551.074 to discuss Personnel by Comm. Grant sec by Comm. Olsen
Carried unanimously
20. No action taken on Executive Session Pursuant to the Texas Government Code Section 551.074 to discuss Personnel

21. 10:41 A. M. Motion to go Executive Session Pursuant to the Texas Government Code Section 551.076 to discuss Security by Comm. Olsen sec by Com. Moore
Carried unanimously

11:51 Motion to come out of Executive Session pursuant to the Texas government Code Section 551.076 to discuss Security by Comm. Moore sec by Comm. Olsen
Carried unanimously

22. No action taken on Executive Session Pursuant to the Texas Government Code 551.076 to discuss Security

23. Motion to adjourn by Comm. Olsen sec Comm. Grant
Carried unanimously

I, Sherry Dowd, Navarro County Clerk, Attest that the Foregoing is a True and accurate accounting of the commissioners Court's authorized proceeding for April 10th, 2017.

Signed 10th day of April, 2017

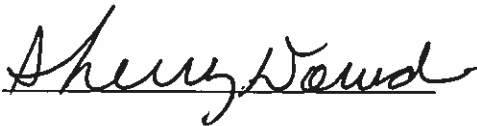

Sherry Dowd, County Clerk



#4

479

NAVARRO COUNTY COMMISSIONERS COURT

PUBLIC COMMENTS PARTICIPATION FORM

PRINT NAME AND SUBJECT

Date 4-10-17

NAME	SUBJECT
1. <u>Melanie Cogh</u>	_____
2. <u>DONALD KINK</u>	<u>GENERAL ITEM</u>
3. <u>John W. Hearley</u> <u>Jackie King</u>	<u>MUSTANG VFI</u> <u>Lesson and Invitation</u> <u>City of Corsicana</u>
4. <u>Donald Kink</u>	_____
5. _____	_____
6. _____	_____
7. _____	_____
8. _____	_____
9. _____	_____
10. _____	_____
11. _____	_____
12. _____	_____

ALL RECORDS FROM 04/10/2017 TO 04/10/2017 DATE-TO-BE-PAID

VENDOR NAME	ACCOUNT #	ACCOUNT NAME	ITEM/REASON	INVOICE #	VP DATE	DATE TBP	PO NO	AMOUNT
ABC FERTILIZER & SUPPLY	2017 101-566-424	WEIGHTS	WEIGHING	25552	04/06/2017	04/10/2017		147.00
ACTION SIGN & BANNER	2017 101-568-445	REPAIRS & MAINT	RESTRIPED MOBILE CO	316	04/06/2017	04/10/2017	302745	1,815.00
ACTION SIGN & BANNER	2017 101-560-445	REPAIRS & MAINT	UNIT 2796 - STRIPED	635	04/07/2017	04/10/2017	303907	185.00
ACTION SIGN & BANNER	2017 101-560-445	REPAIRS & MAINT	UNIT 2795 - STRIPED	635	04/07/2017	04/10/2017	303907	185.00
ACTION SIGN & BANNER	2017 101-560-445	REPAIRS & MAINT	UNIT 2301 - STRIPED	635	04/07/2017	04/10/2017	303907	185.00
ACTION SIGN & BANNER	2017 101-568-445	REPAIRS & MAINT	UNIT 2700 - STRIPED	634	04/07/2017	04/10/2017	303907	875.00
ACTION TARGET INC -TXMA	2017 101-560-429	TRAINING - FIRIN	DLX-90 CYLINDER ASS	100287-1	04/05/2017	04/10/2017	303835	813.96
ACTION TARGET INC -TXMA	2017 101-560-429	TRAINING - FIRIN	DLX-90 MAC VALVE	100287-1	04/05/2017	04/10/2017	303835	557.90
ACTION TARGET INC -TXMA	2017 101-560-429	TRAINING - FIRIN	STL-90/DLX-90 CLAMP	100287-1	04/05/2017	04/10/2017	303835	271.00
ACTION TARGET INC -TXMA	2017 101-560-429	TRAINING - FIRIN	SHIPPING	100287-1	04/05/2017	04/10/2017	303835	15.00
AMERICAN TIRE DISTRIBUT	2017 101-560-325	TIRES	P265/60R17 TIRES	5089494230	04/05/2017	04/10/2017	303674	1,408.32
AT&TSERVICES INC.	2017 101-410-436	INTERNET	125499768 02/23/17	9768 - MAR 2	04/04/2017	04/10/2017		74.26
AT&TSERVICES INC.	2017 101-410-435	TELEPHONE	1717995787 02/18/17	5787 - MAR 2	04/04/2017	04/10/2017		2,047.96
AT&TSERVICES INC.	2017 101-410-435	TELEPHONE	158043660 03/14/17	3660 - MAR 2	04/04/2017	04/10/2017		101.19
AT&TSERVICES INC.	2017 101-410-435	TELEPHONE	287236363034 02/20/	3034 - MAR 2	04/04/2017	04/10/2017		723.16
AT&TSERVICES INC.	2017 101-410-435	TELEPHONE	158051642 03/14/17	1642 - MAR 2	04/04/2017	04/10/2017		101.19
AT&TSERVICES INC.	2017 101-410-435	TELEPHONE	9038751617 03/21/17	1617 - MAR 2	04/06/2017	04/10/2017		3,839.45
AT&TSERVICES INC.	2017 101-410-435	TELEPHONE	9038753391 03/21/17	3391 - MAR 2	04/06/2017	04/10/2017		343.78
AT&TSERVICES INC.	2017 101-560-436	INTERNET	125499763 02/23/17	9763 - MAR 2	04/04/2017	04/10/2017		59.18
ATMOS ENERGY	2017 101-410-430	UTILITIES	4020245287 02/28/17	5287 - MAR 2	04/05/2017	04/10/2017		54.95
ATMOS ENERGY	2017 101-410-430	UTILITIES	4010155456 02/09/17	5456 - MAR 2	04/05/2017	04/10/2017		294.58
B & H PHOTO-VIDEO	2017 101-512-445	REPAIRS & MAINT	SONY EVI-D90 COLOR	124384123	04/05/2017	04/10/2017	303716	919.00
BIZZY BEAR INSTALLATION	2017 101-410-445	REPAIRS & MAINT	COUNTY CLERK - RELO	NCC#1702	04/06/2017	04/10/2017		950.00
BLACKFORD PRINTING CO	2017 101-459-310	OFFICE SUPPLIES	500 ENVELOPES	34267	04/05/2017	04/10/2017	303413	69.00
BLACKFORD PRINTING CO	2017 101-459-310	OFFICE SUPPLIES	1500 WINDOW ENVELOP	34267	04/05/2017	04/10/2017	303413	124.00
BLACKFORD PRINTING CO	2017 101-425-310	OFFICE SUPPLIES	5000 WINDOW ENVELOP	34361	04/06/2017	04/10/2017	303626	294.00
BLACKFORD PRINTING CO	2017 101-405-310	OFFICE SUPPLIES	500 ENVELOPES	34362	04/06/2017	04/10/2017	303591	69.00
BLACKFORD PRINTING CO	2017 101-497-310	OFFICE SUPPLIES	2500 WINDOW ENVELOP	34359	04/06/2017	04/10/2017	303617	197.00
BOB BARKER COMPANY INC	2017 101-512-330	JANITORIAL SUPPL	15.50Z DISINFECTANT	UT1000414082	04/05/2017	04/10/2017	303795	59.00
BOB BARKER COMPANY INC	2017 101-512-350	INMATE SUPPLIES	120Z HAIR CLIPPER S	UT1000414082	04/05/2017	04/10/2017	303795	70.35
BODKIN, NIEHAUS AND DIC	2017 101-435-411	COURT APPOINTED	APPEAL - WATKINS, R	36507	04/06/2017	04/10/2017		2,857.50
CALDWELL COUNTRY CHEVRO	2017 101-568-575	MACHINERY & EQUI	2017 CHEVROLET 2500	HF149812	04/06/2017	04/10/2017	303246	36,886.00
CHATFIELD WATER SUPPLY	2017 101-402-430	UTILITIES - PARK	EUESTER B WILLIAMS	1267 - MAR 2	04/06/2017	04/10/2017		27.00
CHATFIELD WATER SUPPLY	2017 101-512-385	COUNTY FARM	2810 NECR 0080	7 - MAR 2017	04/06/2017	04/10/2017		30.00
CHRIS GARRETT	2017 101-572-428	TRAVEL/CONFERENC	132 MILES @.535	MAR 2017	04/06/2017	04/10/2017		70.62
CITY ELECTRIC	2017 101-410-445	REPAIRS & MAINT	300 W 3RD - LABOR	26320	04/06/2017	04/10/2017	303802	350.00
CITY ELECTRIC	2017 101-410-445	REPAIRS & MAINT	300 W 3RD - INSTALL	26320	04/06/2017	04/10/2017	303802	21.90
CITY ELECTRIC	2017 101-410-445	REPAIRS & MAINT	300 W 3RD - INSTALL	26320	04/06/2017	04/10/2017	303802	96.87
CLASSEN-BUCK SEMINARS	2017 101-560-428	TRAVEL/CONFERENC	RACIAL PROFILING CO	1446-170317	04/05/2017	04/10/2017	303767	25.00
CLASSEN-BUCK SEMINARS	2017 101-560-428	TRAVEL/CONFERENC	ASSET FORFEITURE CO	1446-170317	04/05/2017	04/10/2017	303767	25.00
CLIFFORD POWER SYSTEMS	2017 101-561-445	REPAIRS & MAINT	KOHLER GENERATOR -	SVC-0052421	04/05/2017	04/10/2017	303548	4,149.28
CODY MULDER	2017 101-410-410	PROFESSIONAL SER	02/01/17 - 02/28/17	12	04/06/2017	04/10/2017		2,600.00
COKER'S LAWN SERVICE	2017 101-402-423	SANITARY SERVICE	MOWING PARKS & CLEA	04/03/17	04/06/2017	04/10/2017		2,122.00
CONNIE HICKMAN	2017 101-459-428	TRAVEL/CONFERENC	2017 20 HOUR JP SCH	APR 2017	04/05/2017	04/10/2017		75.76
CONNIE HICKMAN	2017 101-459-428	TRAVEL/CONFERENC	2017 20 HOUR JP SCH	APR 2017	04/05/2017	04/10/2017		178.50
CONNIE HICKMAN	2017 101-459-428	TRAVEL/CONFERENC	2017 20 HOUR JP SCH	HICKMAN, CON	04/05/2017	04/10/2017		220.35
CONSTELLATION NEWENERGY	2017 101-410-430	UTILITIES	10443720008425191	0038578497-0	04/06/2017	04/10/2017		9.50
CORRECTIONS PRODUCTS CO	2017 101-512-445	REPAIRS & MAINT	SHIPPING	48109	04/05/2017	04/10/2017	303777	17.74
CORRECTIONS PRODUCTS CO	2017 101-512-445	REPAIRS & MAINT	REBUILT DOOR LOCKS	48109	04/05/2017	04/10/2017	303777	1,900.00
CORSICANA AIR CONDITION	2017 101-561-446	REPAIRS & MAINT	RICE TOWER - REPLAC	57750	04/07/2017	04/10/2017	303675	2,747.00
CORSICANA GERANIUM GARD	2017 101-410-454	MAINT CONTRACT -	CH YARD MAINTENANCE	5105	04/06/2017	04/10/2017		550.00
CORSICANA GERANIUM GARD	2017 101-411-454	MAINT CONTRACT -	ANNEX YARD MAINTENA	5104	04/06/2017	04/10/2017		300.00
CORWYN DAVIS	2017 101-425-411	COURT APPOINTED	MACK, MIKSHA	73857	04/06/2017	04/10/2017		200.00
CROWNE PLAZA HOTEL	2017 101-560-428	TRAVEL/CONFERENC	TEXAS PUBLIC INFORM	GRIMES, MELI	04/04/2017	04/10/2017		135.00
DAMARA WATKINS	2017 101-425-490	MENTAL / AD LITE	MAR 2017	2017-6	04/06/2017	04/10/2017		100.00

ALL RECORDS FROM 04/10/2017 TO 04/10/2017 DATE-TO-BE-PAID

VENDOR NAME	ACCOUNT #	ACCOUNT NAME	ITEM/REASON	INVOICE #	VP DATE	DATE TBP	PO NO	AMOUNT
DAMARA WATKINS	2017 101-425-490	MENTAL / AD LITE	MAR 2017	2017-7	04/06/2017	04/10/2017		100.00
DAMARA WATKINS	2017 101-425-490	MENTAL / AD LITE	MAR 2017	2017-8	04/06/2017	04/10/2017		200.00
DAMARA WATKINS	2017 101-425-490	MENTAL / AD LITE	MAR 2017	2017-9	04/06/2017	04/10/2017		100.00
DAMARA WATKINS	2017 101-425-490	MENTAL / AD LITE	MAR 2017	2017-10	04/06/2017	04/10/2017		100.00
DANDA PARKER	2017 101-409-490	CHAPTER 19 EXPEN	CERA CERTIFICATION	REIMB - 03/2	04/04/2017	04/10/2017		90.96
DANIEL ROBERT BILTZ	2017 101-430-411	COURT APPOINTED	SMITH, DEMETRIC	36662	04/06/2017	04/10/2017		400.00
DANIEL ROBERT BILTZ	2017 101-430-411	COURT APPOINTED	SMITH, DEMETRIC	36953	04/06/2017	04/10/2017		300.00
DARRELL WALLER	2017 101-457-428	TRAVEL/CONFERENC	2017 20 HOUR JP SCH	WALLER, DARR	04/06/2017	04/10/2017		220.35
DARRELL WALLER	2017 101-457-428	TRAVEL/CONFERENC	2017 20 HOUR JP SCH	APR 2017	04/06/2017	04/10/2017		75.76
DARRELL WALLER	2017 101-457-428	TRAVEL/CONFERENC	2017 20 HOUR JP SCH	APR 2017	04/06/2017	04/10/2017		178.50
DAVID B BROOKS	2017 101-475-410	PROFESSIONAL SER	CONSULTATION - MAR	03/26/17	04/06/2017	04/10/2017		100.00
DEALERS ELECTRICAL SUPP	2017 101-512-321	MAINTENANCE SUPP	BULBS	3311456-00	04/05/2017	04/10/2017	303813	80.40
DEALERS ELECTRICAL SUPP	2017 101-512-321	MAINTENANCE SUPP	BALLAST	3311456-00	04/05/2017	04/10/2017	303813	149.60
DEALERS ELECTRICAL SUPP	2017 101-512-321	MAINTENANCE SUPP	CAT 5E CABLE - GREE	3311385-00	04/05/2017	04/10/2017	303813	123.00
DEALERS ELECTRICAL SUPP	2017 101-512-321	MAINTENANCE SUPP	CAT 5E CABLE - YELL	3311385-00	04/05/2017	04/10/2017	303813	123.00
DEALERS ELECTRICAL SUPP	2017 101-512-321	MAINTENANCE SUPP	64W LED WALL PACK	3311362-00	04/05/2017	04/10/2017	303793	333.27
DEALERS ELECTRICAL SUPP	2017 101-410-321	MAINTENANCE SUPP	LAMPS	3311461-00	04/06/2017	04/10/2017	302566	73.74
DEALERS ELECTRICAL SUPP	2017 101-410-321	MAINTENANCE SUPP	DISCOUNT	3311461-00	04/06/2017	04/10/2017	302566	74.00
DEALERS ELECTRICAL SUPP	2017 101-512-385	COUNTY FARM	DIM FUSES	3311569-00	04/07/2017	04/10/2017	303662	9.45
DISTRICT 8 TEAFCS	2017 101-421-428	TRAVEL/CONFERENC	2017 TEA-FCS CONF -	STOVALL, LOR	04/05/2017	04/10/2017		225.00
DOUGLAS EQUIPMENT	2017 101-512-325	KITCHEN SUPPLIES	4QT FOOD STORAGE CO	25014	04/05/2017	04/10/2017	303722	32.34
DOUGLAS EQUIPMENT	2017 101-512-325	KITCHEN SUPPLIES	2QT-4QT LIDS - GREE	25014	04/05/2017	04/10/2017	303722	4.80
DOUGLAS EQUIPMENT	2017 101-512-325	KITCHEN SUPPLIES	6QT FOOD STORAGE CO	25014	04/05/2017	04/10/2017	303722	46.14
DOUGLAS EQUIPMENT	2017 101-512-325	KITCHEN SUPPLIES	6QT-8QT LIDS - RED	25014	04/05/2017	04/10/2017	303722	7.38
DOUGLAS EQUIPMENT	2017 101-512-325	KITCHEN SUPPLIES	8QT FOOD STORAGE CO	25014	04/05/2017	04/10/2017	303722	54.06
DOUGLAS EQUIPMENT	2017 101-512-325	KITCHEN SUPPLIES	6QT-8QT LIDS - RED	25014	04/05/2017	04/10/2017	303722	7.38
DOUGLAS EQUIPMENT	2017 101-512-325	KITCHEN SUPPLIES	4QT ROUND STORAGE C	25014	04/05/2017	04/10/2017	303722	34.62
DOUGLAS EQUIPMENT	2017 101-512-325	KITCHEN SUPPLIES	2QT-4QT ROUND LIDS	25014	04/05/2017	04/10/2017	303722	10.20
DOUGLAS EQUIPMENT	2017 101-512-325	KITCHEN SUPPLIES	6QT ROUND STORAGE C	25014	04/05/2017	04/10/2017	303722	44.76
DOUGLAS EQUIPMENT	2017 101-512-325	KITCHEN SUPPLIES	6QT-8QT ROUND LIDS	25014	04/05/2017	04/10/2017	303722	15.54
DOUGLAS EQUIPMENT	2017 101-512-325	KITCHEN SUPPLIES	SHIPPING	25014	04/05/2017	04/10/2017	303722	25.93
DOUGLAS EQUIPMENT	2017 101-512-325	KITCHEN SUPPLIES	5 PC MEASURING CUP	25014	04/05/2017	04/10/2017	303722	20.48
DOWD & SONS INC	2017 101-560-445	REPAIRS & MAINT	UNIT 2584 - REPLACE	0110887	04/05/2017	04/10/2017	303798	225.00
ELECTION CENTER	2017 101-409-490	CHAPTER 19 EXPEN	CERA GRADUATION - R	PARKER, DAND	04/04/2017	04/10/2017		175.00
ELECTION SYSTEMS & SOFT	2017 101-409-425	ELECTIONS	BALLOTS 05/06/17	1004011	04/06/2017	04/10/2017		276.49
ELECTION SYSTEMS & SOFT	2017 101-409-425	ELECTIONS	CODING 05/06/17 ELE	1005079	04/06/2017	04/10/2017		3,213.84
FEDEX - TXMAS	2017 101-406-311	POSTAGE	2934-0047-4	5-747-61525	04/04/2017	04/10/2017		89.70
FIVE STAR SERVICES INC	2017 101-512-380	GROCERIES	03/23/17 - 03/29/17	27171	04/07/2017	04/10/2017		5,178.38
FRANK KENT COUNTRY LLC	2017 101-560-445	REPAIRS & MAINT	PLASTIC CLIPS	NAV001	04/05/2017	04/10/2017	303851	65.00
FRANK KENT COUNTRY LLC	2017 101-560-445	REPAIRS & MAINT	2017 CHEVY - REMOTE	NAV001	04/05/2017	04/10/2017	303851	72.00
FRANK KENT COUNTRY LLC	2017 101-560-445	REPAIRS & MAINT	2017 CHEVY - KEYS	NAV001	04/05/2017	04/10/2017	303851	145.96
GABRIELLE MASSEY	2017 101-475-428	TRAVEL/CONFERENC	SPECIAL PROSECTON	REIMB - 03/2	04/06/2017	04/10/2017		119.60
GABRIELLE MASSEY	2017 101-475-428	TRAVEL/CONFERENC	SPECIAL PROSECTON	REIMB - 03/2	04/06/2017	04/10/2017		119.11
GALLS LLC	2017 101-560-426	UNIFORMS	LS SHIRTS - VASQUEZ	007214415	04/05/2017	04/10/2017	303693	77.62
GALLS LLC	2017 101-560-426	UNIFORMS	SS SHIRTS - VASQUEZ	007214415	04/05/2017	04/10/2017	303693	104.25
GALLS LLC	2017 101-560-426	UNIFORMS	CLASS A PANTS - VAS	007214415	04/05/2017	04/10/2017	303693	51.50
GALLS LLC	2017 101-560-426	UNIFORMS	CLASS B PANTS - VAS	007214415	04/05/2017	04/10/2017	303693	66.00
GALLS LLC	2017 101-560-321	RESERVE FOR ENCU	BLACKHAWK PRO SHOOT	007257373	04/05/2017	04/10/2017	303847	130.04
GALLS LLC	2017 101-560-426	UNIFORMS	LS SHIRTS - RIDER,	007198632	04/05/2017	04/10/2017	303749	77.62
GALLS LLC	2017 101-560-426	UNIFORMS	SS SHIRTS - RIDER,	007198632	04/05/2017	04/10/2017	303749	69.50
GALLS LLC	2017 101-560-426	UNIFORMS	SS SHIRTS - LLOYD,	007198630	04/05/2017	04/10/2017	303749	104.25
GALLS LLC	2017 101-560-426	UNIFORMS	SS SHIRTS - ESPINOS	007214485	04/05/2017	04/10/2017	303749	104.25
GALLS LLC	2017 101-560-320	OPERATING EQUIPM	BLACKHAWK STORM SLI	007190345	04/06/2017	04/10/2017	303334	80.97
GALLS LLC	2017 101-560-426	UNIFORMS	LS SHIRTS - LARREMO	007172159	04/06/2017	04/10/2017	303606	76.00
GALLS LLC	2017 101-560-426	UNIFORMS	LS SHIRTS - LARREMO	007248735	04/06/2017	04/10/2017	303606	76.00

ALL RECORDS FROM 04/10/2017 TO 04/10/2017 DATE-TO-BE-PAID

VENDOR NAME	ACCOUNT #	ACCOUNT NAME	ITEM/REASON	INVOICE #	VP DATE	DATE TBP	PO NO	AMOUNT
GALLS LLC	2017 101-560-426	UNIFORMS	REFERENCE TO INV 00	007270955	04/06/2017	04/10/2017	303606	76.00-
GEXA ENERGY - DALLAS	2017 101-410-430	UTILITIES	800 N MAIN ST 02/16	2074319-3 -	04/04/2017	04/10/2017		904.92
GEXA ENERGY - DALLAS	2017 101-412-430	UTILITIES	313 W 3RD AVE 02/21	2346187-3 -	04/04/2017	04/10/2017		70.66
GEXA ENERGY - DALLAS	2017 101-512-435	UTILITIES	516 N 13TH ST 02/27	2320241-3 -	04/06/2017	04/10/2017		38.90
GEXA ENERGY - DALLAS	2017 101-411-430	UTILITIES	601 N 13TH ST GRDL	2147076-3 -	04/06/2017	04/10/2017		39.32
GEXA ENERGY - HOUSTON	2017 101-410-430	UTILITIES	300 W 3RD AVE UNIT	22931073-4	04/04/2017	04/10/2017		2,326.50
GEXA ENERGY - HOUSTON	2017 101-512-435	UTILITIES	312 W 2ND AVE GRDL	22931073-4	04/04/2017	04/10/2017		32.76
GEXA ENERGY - HOUSTON	2017 101-410-430	UTILITIES	300 W 3RD AVE GRDL	22931073-4	04/04/2017	04/10/2017		14.03
GEXA ENERGY - HOUSTON	2017 101-410-430	UTILITIES	300 W 3RD AVE GRDL	22931073-4	04/04/2017	04/10/2017		18.12
GEXA ENERGY - HOUSTON	2017 101-410-430	UTILITIES	300 N 13TH ST TEMP	22931073-4	04/04/2017	04/10/2017		9.50
GEXA ENERGY - HOUSTON	2017 101-410-430	UTILITIES	300 W 3RD AVE TEMP	22931073-4	04/04/2017	04/10/2017		9.50
GEXA ENERGY - HOUSTON	2017 101-512-435	UTILITIES	312 W 2ND AVE 02/21	22931073-4	04/04/2017	04/10/2017		5,365.64
GEXA ENERGY - HOUSTON	2017 101-410-430	UTILITIES	300 W 3RD AVE TEMP	22931073-4	04/04/2017	04/10/2017		9.50
GEXA ENERGY - HOUSTON	2017 101-412-430	UTILITIES	315 W 3RD AVE STE B	22931073-4	04/04/2017	04/10/2017		40.78
GEXA ENERGY - HOUSTON	2017 101-412-430	UTILITIES	315 W 3RD AVE STE A	22931073-4	04/04/2017	04/10/2017		181.85
GOVERNMENT FINANCE OFFI	2017 101-406-410	PROFESSIONAL SER	141625001 - COA APP	FY2016	04/07/2017	04/10/2017		435.00
GT DISTRIBUTORS INC	2017 101-560-429	TRAINING - FIRIN	.308 WIN 20/BS SIER	INV0611545	04/05/2017	04/10/2017	303834	710.00
GT DISTRIBUTORS INC	2017 101-560-429	TRAINING - FIRIN	SHIPPING	INV0611545	04/05/2017	04/10/2017	303834	9.95
H E B GROCERY #238 100	2017 101-512-380	GROCERIES	ORANGES - CASE	065414	04/05/2017	04/10/2017	303833	23.94
H E B GROCERY #238 100	2017 101-512-380	GROCERIES	EGGS - CASE	065414	04/05/2017	04/10/2017	303833	11.85
HILL PLUMBING SERVICE	2017 101-412-445	REPAIRS & MAINT	313 W 3RD - INSTALL	19788	04/06/2017	04/10/2017	303280	450.00
HOME DEPOT CREDIT SERVI	2017 101-512-321	MAINTENANCE SUPP	18V CORDLESS HAMMER	4120256	04/05/2017	04/10/2017	303852	299.00
HOME DEPOT CREDIT SERVI	2017 101-512-321	MAINTENANCE SUPP	ALUMINUM ANGLE	4120256	04/05/2017	04/10/2017	303852	45.10
HOME DEPOT CREDIT SERVI	2017 101-512-321	MAINTENANCE SUPP	SATURN PASSAGE KNOB	4120256	04/05/2017	04/10/2017	303852	8.96
HOWARD'S FIRE EXTINGUIS	2017 101-411-445	REPAIRS & MAINT	601 N 13TH ST - ANN	061089	04/06/2017	04/10/2017	303844	109.75
HUFFMAN COMMUNICATIONS	2017 101-512-445	REPAIRS & MAINT	MOTOROLA CP-185 BAT	35218	04/06/2017	04/10/2017	303819	414.00
HUFFMAN COMMUNICATIONS	2017 101-512-445	REPAIRS & MAINT	MOTOROLA CP-185 MIC	35218	04/06/2017	04/10/2017	303819	296.00
HUFFMAN COMMUNICATIONS	2017 101-561-446	REPAIRS & MAINT	MAINTENANCE AGREEME	46750	04/07/2017	04/10/2017		105.00
HYATT REGENCY LOST PINE	2017 101-497-428	TRAVEL/CONFERENC	45TH ANNUAL TREASUR	DOUGLAS, RYA	04/04/2017	04/10/2017		576.73
HYATT REGENCY LOST PINE	2017 101-497-428	TRAVEL/CONFERENC	45TH ANNUAL TREASUR	MCCOLLUM, JA	04/04/2017	04/10/2017		576.73
IFEYINWA J. SEALS	2017 101-435-411	COURT APPOINTED	RAINDLE, KRTAVIS	37127	04/04/2017	04/10/2017		725.00
IJS COMPANY	2017 101-410-330	JANITORIAL SUPPL	BROOM-WAREHOUSE, FA	140224	04/07/2017	04/10/2017	302562	64.07
JACKIE FREELAND	2017 101-458-428	TRAVEL/CONFERENC	2017 20 HOUR JP SCH	FREELAND, JA	04/04/2017	04/10/2017		220.35
JACKIE FREELAND	2017 101-458-428	TRAVEL/CONFERENC	2017 20 HOUR JP SCH	APR 2017	04/04/2017	04/10/2017		178.50
JACKIE FREELAND	2017 101-458-428	TRAVEL/CONFERENC	2017 20 HOUR JP SCH	APR 2017	04/04/2017	04/10/2017		75.97
JANE MCCOLLUM	2017 101-497-428	TRAVEL/CONFERENC	45TH ANNUAL TREASUR	APR 2017	04/04/2017	04/10/2017		178.50
JANE MCCOLLUM	2017 101-497-428	TRAVEL/CONFERENC	45TH ANNUAL TREASUR	APR 2017	04/04/2017	04/10/2017		188.32
JUANITA B EDGECOMB PC	2017 101-435-411	COURT APPOINTED	ZONA, CLAY	37089	04/06/2017	04/10/2017		825.00
K & S TIRE TOWING & REC	2017 101-560-445	REPAIRS & MAINT	UNIT 2585 - OIL CHA	65802	04/05/2017	04/10/2017	303073	94.41
K & S TIRE TOWING & REC	2017 101-560-445	REPAIRS & MAINT	UNIT 2585 - TOWED	65723	04/05/2017	04/10/2017	303073	45.00
K & S TIRE TOWING & REC	2017 101-560-445	REPAIRS & MAINT	UNIT 2945 - REPAIRE	65596	04/05/2017	04/10/2017	303073	10.00
K & S TIRE TOWING & REC	2017 101-560-445	REPAIRS & MAINT	UNIT 2473 - REPAIRE	65338	04/05/2017	04/10/2017	303073	55.00
K & S TIRE TOWING & REC	2017 101-560-445	REPAIRS & MAINT	UNIT 2475 - OIL CHA	65698	04/05/2017	04/10/2017	303073	56.95
K & S TIRE TOWING & REC	2017 101-560-445	REPAIRS & MAINT	UNIT 2153 - OIL CHA	65689	04/05/2017	04/10/2017	303073	32.94
K & S TIRE TOWING & REC	2017 101-560-445	REPAIRS & MAINT	UNIT 2473 - ROTATED	65452	04/05/2017	04/10/2017	303073	20.00
K & S TIRE TOWING & REC	2017 101-560-445	REPAIRS & MAINT	UNIT 2688 - OIL CHA	65370	04/05/2017	04/10/2017	303073	61.45
K & S TIRE TOWING & REC	2017 101-560-445	REPAIRS & MAINT	UNIT 2263 - REPLACE	65761	04/05/2017	04/10/2017	303073	51.48
K & S TIRE TOWING & REC	2017 101-560-445	REPAIRS & MAINT	UNIT 2369 - REPLACE	65730	04/06/2017	04/10/2017	303838	193.41
K & S TIRE TOWING & REC	2017 101-560-445	REPAIRS & MAINT	UNIT 2831 - SERVICE	65818	04/07/2017	04/10/2017	303073	69.00
K & S TIRE TOWING & REC	2017 101-560-445	REPAIRS & MAINT	UNIT 2581 - REPLACE	65810	04/07/2017	04/10/2017	303880	389.95
KEATHLEY & KEATHLEY	2017 101-430-411	COURT APPOINTED	THOMPSON, RICHARD	36123	04/06/2017	04/10/2017		200.00
KEATHLEY & KEATHLEY	2017 101-435-411	COURT APPOINTED	MCCULLEN, MARSHALL	36620	04/06/2017	04/10/2017		1,062.50
KEATHLEY & KEATHLEY	2017 101-430-411	COURT APPOINTED	ARISMEDEZ, JESSE	37100	04/06/2017	04/10/2017		400.00
KEATHLEY & KEATHLEY	2017 101-430-411	COURT APPOINTED	ARISMEDEZ, JESSE	37102	04/06/2017	04/10/2017		300.00
KEATHLEY & KEATHLEY	2017 101-435-411	COURT APPOINTED	THOMPSON, RICHARD	36019	04/06/2017	04/10/2017		200.00

ALL RECORDS FROM 04/10/2017 TO 04/10/2017 DATE-TO-BE-PAID

VENDOR NAME	ACCOUNT #	ACCOUNT NAME	ITEM/REASON	INVOICE #	VP DATE	DATE TBP	PO NO	AMOUNT
KEATHLEY & KEATHLEY	2017 101-435-411	COURT APPOINTED	THOMPSON, RICHARD	36017	04/06/2017	04/10/2017		200.00
KEATHLEY & KEATHLEY	2017 101-435-411	COURT APPOINTED	THOMAS, NICOLE	NOT INDICTED	04/06/2017	04/10/2017		100.00
KEATHLEY & KEATHLEY	2017 101-435-485	OTHER LITIGATION	ITIO	13664	04/06/2017	04/10/2017		.76
KEATHLEY & KEATHLEY	2017 101-435-490	MENTAL / AD LITE	ITIO	13664	04/06/2017	04/10/2017		237.50
KELLY R MYERS, ATTORNEY	2017 101-435-490	MENTAL / AD LITE	ITIO	24943	04/06/2017	04/10/2017		875.00
KELLY R MYERS, ATTORNEY	2017 101-435-490	MENTAL / AD LITE	ITIO	22343	04/06/2017	04/10/2017		250.00
KLEEN-AIR FILTER SERVIC	2017 101-512-450	MAINT CONTRACT -	REPLACED AIR FILTER	158738	04/06/2017	04/10/2017		680.00
L-3 COM MOBILE-VISION I	2017 101-560-446	REPAIRS & MAINT	13' FB CONTROL CABL	0253761-IN	04/06/2017	04/10/2017	303752	47.95
L-3 COM MOBILE-VISION I	2017 101-560-446	REPAIRS & MAINT	THRU-HOLE ANTENNA -	0253761-IN	04/06/2017	04/10/2017	303752	119.00
L-3 COM MOBILE-VISION I	2017 101-560-446	REPAIRS & MAINT	FRONT RADAR INTERFA	0253761-IN	04/06/2017	04/10/2017	303752	25.00
L-3 COM MOBILE-VISION I	2017 101-560-446	REPAIRS & MAINT	SHIPPING	0253761-IN	04/06/2017	04/10/2017	303752	14.00
LABOR LAW CENTER, INC	2017 101-406-315	FORMS & PRINTING	TEXAS & FEDERAL LAB	100432192	04/05/2017	04/10/2017	303803	239.60
LABOR LAW CENTER, INC	2017 101-406-315	FORMS & PRINTING	TEXAS & FEDERAL LAB	100432838	04/06/2017	04/10/2017	303842	89.85
LAW OFFICE OF JASON ALL	2017 101-435-411	COURT APPOINTED	WASHINGTON, MATTHEW	37087	04/06/2017	04/10/2017		762.50
LAW OFFICE OF JASON ALL	2017 101-425-411	COURT APPOINTED	GALVAN, OSBALDO GIR	73597	04/06/2017	04/10/2017		100.00
LAW OFFICE OF JASON ALL	2017 101-435-485	OTHER LITIGATION	DAVIS, THOMAS	33536	04/06/2017	04/10/2017		3.00
LAW OFFICE OF JASON ALL	2017 101-435-411	COURT APPOINTED	DAVIS, THOMAS	33536	04/06/2017	04/10/2017		800.00
LAW OFFICE OF KERRI AND	2017 101-435-411	COURT APPOINTED	JUVENILE	2207	04/06/2017	04/10/2017		300.00
LAW OFFICE OF KERRI AND	2017 101-435-411	COURT APPOINTED	HILL, STEPHANIE	35997	04/06/2017	04/10/2017		200.00
LENOVO FINANCIAL SERVIC	2017 101-440-320	OPERATING EQUIPM	908-0008685-000 - M	30043348	04/04/2017	04/10/2017		652.10
LENOVO FINANCIAL SERVIC	2017 101-495-320	OPERATING EQUIPM	908-0009025-000 - A	30059835	04/06/2017	04/10/2017		466.53
LENOVO FINANCIAL SERVIC	2017 101-495-320	OPERATING EQUIPM	902-0010608-000 - A	30074835	04/06/2017	04/10/2017		581.14
LESLIE KIRK CSR	2017 101-435-412	TRANSCRIPTS	HERVEY, MARCUS 3680	4	04/06/2017	04/10/2017		56.46
LESLIE KIRK CSR	2017 101-435-412	TRANSCRIPTS	HERVEY, MARCUS 3680	5	04/06/2017	04/10/2017		165.00
LESLIE KIRK CSR	2017 101-435-412	TRANSCRIPTS	WILSON, ANTONIO 366	3	04/06/2017	04/10/2017		3,371.75
LEXIS NEXIS - DALLAS	2017 101-440-419	DUES & SUBSCRIPT	424TQ567H 03/01/17	3090912282	04/06/2017	04/10/2017		161.00
LISA A EASLEY	2017 101-430-412	TRANSCRIPTS	RUSSAW, ALANDIS - 3	0067	04/06/2017	04/10/2017		2,325.00
MCCOY'S BUILDING SUPPLY	2017 101-512-321	MAINTENANCE SUPP	CONCRETE MIX, MARKI	5912777	04/05/2017	04/10/2017	302478	28.36
MCCOY'S BUILDING SUPPLY	2017 101-512-321	MAINTENANCE SUPP	40AC FENCE CHARGER	5912960	04/05/2017	04/10/2017	302478	56.14
MCCOY'S BUILDING SUPPLY	2017 101-512-321	MAINTENANCE SUPP	51" PINCH POINT BAR	5912996	04/05/2017	04/10/2017	302478	27.29
MCCOY'S BUILDING SUPPLY	2017 101-410-330	JANITORIAL SUPPL	LATEX GLOVES	5913053	04/07/2017	04/10/2017	302565	1.92
MCCOY'S BUILDING SUPPLY	2017 101-410-321	MAINTENANCE SUPP	2.5' POWER STRIP, S	5913053	04/07/2017	04/10/2017	302565	26.14
MEDICAL SURGICAL & COMP	2017 101-572-411	NON-RESIDENTIAL	PRE-EMPLOYMENT DRUG	5419	04/05/2017	04/10/2017		28.50
MELANIE HYDER	2017 101-572-428	TRAVEL/CONFERENC	677 MILES @ .535	MAR 2017	04/06/2017	04/10/2017		362.20
MELISSA GRIMES	2017 101-560-428	TRAVEL/CONFERENC	TEXAS PUBLIC INFORM	APR 2017	04/04/2017	04/10/2017		76.50
MEN WATER SUPPLY CORP	2017 101-402-430	UTILITIES - PARK	CASTON PARK	775 - MAR 20	04/07/2017	04/10/2017		38.33
METRO-REPRO, INC.	2017 101-403-310	OFFICE SUPPLIES	36 X 500 BOND PAPER	28735	04/06/2017	04/10/2017	303804	66.30
METRO-REPRO, INC.	2017 101-403-310	OFFICE SUPPLIES	SHIPPING	28735	04/06/2017	04/10/2017	303804	5.00
NATIONAL WHOLESALE SUPP	2017 101-411-321	MAINTENANCE SUPP	601 N 13TH - 14 X 3	S2134205.001	04/06/2017	04/10/2017	303809	102.94
NATIONAL WHOLESALE SUPP	2017 101-412-321	MAINTENANCE SUPP	317 W 3RD - 12 X 12	S2134205.001	04/06/2017	04/10/2017	303809	41.73
NATIONAL WHOLESALE SUPP	2017 101-412-321	MAINTENANCE SUPP	313 W 3RD - 24 X 24	S2134205.001	04/06/2017	04/10/2017	303809	53.97
NATIONAL WHOLESALE SUPP	2017 101-412-321	MAINTENANCE SUPP	315 W 3RD - 16 X 24	S2134205.001	04/06/2017	04/10/2017	303809	91.81
NATIONAL WHOLESALE SUPP	2017 101-412-321	MAINTENANCE SUPP	315 W 3RD - 12 X 30	S2142449.001	04/06/2017	04/10/2017	303867	40.80
NATIONAL WHOLESALE SUPP	2017 101-412-321	MAINTENANCE SUPP	315 W 3RD - 12 X 20	S2142449.001	04/06/2017	04/10/2017	303867	85.50
NATIONAL WHOLESALE SUPP	2017 101-412-321	MAINTENANCE SUPP	601 N 13TH ST - HS3	S2138743.001	04/06/2017	04/10/2017	303832	118.19
NATIONAL WHOLESALE SUPP	2017 101-410-321	MAINTENANCE SUPP	300 W 3RD - 4V410HD	S2138743.001	04/06/2017	04/10/2017	303832	282.78
NAVARRO CO TAX ASSESSOR	2017 101-560-445	REPAIRS & MAINT	REGISTRATION - 1FBS	03/23/17	04/05/2017	04/10/2017		7.50
NAVARRO CO TAX ASSESSOR	2017 101-560-445	REPAIRS & MAINT	REGISTRATION - 1GNL	03/30/17	04/06/2017	04/10/2017		7.50
NAVARRO CO TAX ASSESSOR	2017 101-560-445	REPAIRS & MAINT	REGISTRATION - 1GC1	03/20/17	04/06/2017	04/10/2017		16.75
NAVARRO CO TAX ASSESSOR	2017 101-560-445	REPAIRS & MAINT	REGISTRATION - 1GNL	04/06/17	04/07/2017	04/10/2017		7.50
NAVARRO CO TAX ASSESSOR	2017 101-560-445	REPAIRS & MAINT	REGISTRATION - 1GNL	03/22/17	04/07/2017	04/10/2017		7.50
NAVARRO COUNTY ELECTRIC	2017 101-402-430	UTILITIES - PARK	13260500 - HWY 0309	0500 - MAR 2	04/07/2017	04/10/2017		12.67
NAVARRO COUNTY ELECTRIC	2017 101-512-435	UTILITIES	11255700 - HWY 0022	5700 - MAR 2	04/07/2017	04/10/2017		116.00
NAVARRO COUNTY ELECTRIC	2017 101-512-435	UTILITIES	14707000 - FM 0667	7000 - MAR 2	04/07/2017	04/10/2017		35.00
NAVARRO COUNTY ELECTRIC	2017 101-512-435	UTILITIES	15514400 - MCKINNEY	4400 - MAR 2	04/07/2017	04/10/2017		37.00

ALL RECORDS FROM 04/10/2017 TO 04/10/2017 DATE-TO-BE-PAID

VENDOR NAME	ACCOUNT #	ACCOUNT NAME	ITEM/REASON	INVOICE #	VP DATE	DATE TBP	PO NO	AMOUNT
NAVARRO COUNTY ELECTRIC	2017 101-402-430	UTILITIES - PARK	13258900 - SECR 109 8900 - MAR 2	04/07/2017	04/10/2017			12.67
NAVARRO COUNTY ELECTRIC	2017 101-402-430	UTILITIES - PARK	13259700 - SECR 216 9700 - MAR 2	04/07/2017	04/10/2017			10.35
NAVARRO COUNTY ELECTRIC	2017 101-402-430	UTILITIES - PARK	13767900 - SECR 310 7900 - MAR 2	04/07/2017	04/10/2017			23.02
NAVCO SAFE & LOCK COMPA	2017 101-560-321	RESERVE FOR ENCU	PADLOCKS, KEYS, KEY	5031405	04/05/2017	04/10/2017	302941	88.33
NEAL GREEN	2017 101-430-411	COURT APPOINTED	SANDERS, EDWARD	36321 (2)	04/06/2017	04/10/2017		225.00
NEAL GREEN	2017 101-425-411	COURT APPOINTED	WILLIAMS, CHARLES	72814	04/06/2017	04/10/2017		100.00
NEAL GREEN	2017 101-425-411	COURT APPOINTED	PERRITT, ROBERT	72996	04/06/2017	04/10/2017		200.00
NEAL GREEN	2017 101-425-411	COURT APPOINTED	CHATMAN, REGINALD	73991	04/06/2017	04/10/2017		100.00
NEAL GREEN	2017 101-425-411	COURT APPOINTED	CHATMAN, REGINALD	73992	04/06/2017	04/10/2017		50.00
NEAL GREEN	2017 101-425-411	COURT APPOINTED	CHATMAN, REGINALD	73910	04/06/2017	04/10/2017		200.00
NEAL GREEN	2017 101-425-411	COURT APPOINTED	HIGH, CORY SCOTT	69628	04/06/2017	04/10/2017		100.00
NEAL GREEN	2017 101-425-411	COURT APPOINTED	HIGH, CORY SCOTT	70318	04/06/2017	04/10/2017		50.00
NEAL GREEN	2017 101-425-411	COURT APPOINTED	HIGH, CORY SCOTT	69722	04/06/2017	04/10/2017		50.00
NEAL GREEN	2017 101-425-411	COURT APPOINTED	HIGH, CORY SCOTT	73515	04/06/2017	04/10/2017		50.00
NEAL GREEN	2017 101-425-411	COURT APPOINTED	ARREDONDA, GERARDO	73918	04/06/2017	04/10/2017		50.00
NEAL GREEN	2017 101-425-411	COURT APPOINTED	ARREDONDA, GERARDO	73919	04/06/2017	04/10/2017		50.00
NEAL GREEN	2017 101-425-411	COURT APPOINTED	FALLS, GAINES	73566	04/06/2017	04/10/2017		50.00
NEAL GREEN	2017 101-425-411	COURT APPOINTED	ARREDONDA, GERARDO	73591	04/06/2017	04/10/2017		100.00
NEAL GREEN	2017 101-425-411	COURT APPOINTED	FALLS, GAINES	73488	04/06/2017	04/10/2017		100.00
NETMOTION WIRELESS INC	2017 101-560-340	INVESTIGATIVE /	MAINTENANCE 06/15/1	I0035765	04/07/2017	04/10/2017		5,664.83
NEW LONDON TECHNOLOGY I	2017 101-561-446	REPAIRS & MAINT	HYTERA TM610V RECEI	AD-0513	04/06/2017	04/10/2017	303812	215.00
NEW LONDON TECHNOLOGY I	2017 101-561-446	REPAIRS & MAINT	SHIPPING	AD-0513	04/06/2017	04/10/2017	303812	16.92
NEW LONDON TECHNOLOGY I	2017 101-560-446	REPAIRS & MAINT	M7100 CONTROL CABLE	AD-0480	04/06/2017	04/10/2017	303751	80.00
NEW LONDON TECHNOLOGY I	2017 101-560-446	REPAIRS & MAINT	M7100 POWER CABLE	AD-0480	04/06/2017	04/10/2017	303751	107.00
NEW LONDON TECHNOLOGY I	2017 101-560-446	REPAIRS & MAINT	SHIPPING	AD-0480	04/06/2017	04/10/2017	303751	16.62
NORMAN LEE STUBBS	2017 101-572-445	REPAIRS & MAINT	315 W 3RD - LABOR	075530	04/06/2017	04/10/2017	303870	685.00
OFFICE DEPOT INC-TXMAS	2017 101-421-310	OFFICE SUPPLIES	DESK PLATE - EXTENS	910590754001	04/05/2017	04/10/2017	303725	29.99
OFFICE DEPOT INC-TXMAS	2017 101-512-310	OFFICE SUPPLIES	CD/DVD SLEEVES	913414401001	04/05/2017	04/10/2017	303772	24.04
OFFICE DEPOT INC-TXMAS	2017 101-512-310	OFFICE SUPPLIES	RUBBER FINGERTIPS	913414400001	04/05/2017	04/10/2017	303772	6.58
OFFICE DEPOT INC-TXMAS	2017 101-512-310	OFFICE SUPPLIES	CANNED AIR, RUBBER	913414244001	04/05/2017	04/10/2017	303772	68.98
OFFICE DEPOT INC-TXMAS	2017 101-512-330	JANITORIAL SUPPL	KIMTECH KIMWIPES	913414244001	04/05/2017	04/10/2017	303772	25.95
OFFICE DEPOT INC-TXMAS	2017 101-421-310	OFFICE SUPPLIES	CLASP ENVELOPES, NA	910590860001	04/05/2017	04/10/2017	303725	16.47
OFFICE DEPOT INC-TXMAS	2017 101-421-310	OFFICE SUPPLIES	BRIGHT WHITE PAPER	915338781001	04/06/2017	04/10/2017	303817	7.75
OFFICE DEPOT INC-TXMAS	2017 101-421-310	OFFICE SUPPLIES	VERTICLE FILE CABIN	915338781001	04/06/2017	04/10/2017	303817	279.98
OFFICE DEPOT INC-TXMAS	2017 101-421-310	OFFICE SUPPLIES	HP 920XL INK - YELL	915338780001	04/06/2017	04/10/2017	303817	19.99
OFFICE DEPOT INC-TXMAS	2017 101-475-310	OFFICE SUPPLIES	LITERATURE SORTER,	912533138001	04/06/2017	04/10/2017	303769	209.54
OFFICE DEPOT INC-TXMAS	2017 101-475-310	OFFICE SUPPLIES	COFFEE, CREAMER, SU	913056686001	04/06/2017	04/10/2017	303769	140.50
OFFICE DEPOT INC-TXMAS	2017 101-475-310	OFFICE SUPPLIES	5-DRAWER LEGAL FILE	914218451001	04/06/2017	04/10/2017	303787	531.99
OFFICE DEPOT INC-TXMAS	2017 101-403-310	OFFICE SUPPLIES	ADDRESS LABELS, TAP	915193636001	04/06/2017	04/10/2017	303816	106.22
OFFICE DEPOT INC-TXMAS	2017 101-403-310	OFFICE SUPPLIES	HP 81A TONER - BLAC	915193636001	04/06/2017	04/10/2017	303816	180.99
OFFICE DEPOT INC-TXMAS	2017 101-403-310	OFFICE SUPPLIES	ENVELOPES	915526882001	04/06/2017	04/10/2017	303816	35.58
OFFICE DEPOT INC-TXMAS	2017 101-406-312	COPY & POSTAGE S	COPY PAPER	914680257001	04/06/2017	04/10/2017	303818	74.88
OFFICE DEPOT INC-TXMAS	2017 101-560-310	OFFICE SUPPLIES	BIG & TALL EXECUTIV	914719864001	04/06/2017	04/10/2017	303815	381.99
OLSEN FEED & SUPPLY	2017 101-512-385	COUNTY FARM	PLANTS	366992	04/05/2017	04/10/2017	302494	21.60
OLSEN FEED & SUPPLY	2017 101-512-385	COUNTY FARM	PLANTS	366997	04/05/2017	04/10/2017	302494	7.20
OLSEN FEED & SUPPLY	2017 101-512-385	COUNTY FARM	150Z SQUASH SEEDS	372666	04/05/2017	04/10/2017	302494	17.00
OLSEN FEED & SUPPLY	2017 101-512-385	COUNTY FARM	FERTILIZER	372695	04/05/2017	04/10/2017	302494	33.90
OLSEN FEED & SUPPLY	2017 101-512-385	COUNTY FARM	PLANTS	372685	04/05/2017	04/10/2017	302494	86.40
ORKIN PEST CONTROL	2017 101-512-456	MAINT CONTRACT -	70772 - 312 W 2ND A	346602	04/05/2017	04/10/2017		128.75
ORKIN PEST CONTROL	2017 101-410-456	MAINT CONTRACT -	70772 - 300 W 3RD	347210	04/06/2017	04/10/2017		83.62
OWEN HARDWARE INC	2017 101-512-321	MAINTENANCE SUPP	8' POWER CORD	AA59650	04/05/2017	04/10/2017	302477	11.98
OWEN HARDWARE INC	2017 101-512-321	MAINTENANCE SUPP	DRILL BITS	AA59585	04/05/2017	04/10/2017	302477	8.97
PCMG INC	2017 101-512-445	REPAIRS & MAINT	4TB SURVEILLANCE HA	B02295110101	04/06/2017	04/10/2017	303758	408.00
PCMG INC	2017 101-512-445	REPAIRS & MAINT	SHIPPING	B02295110101	04/06/2017	04/10/2017	303758	8.00
PHILIP R TAFT PSY	2017 101-435-470	MEDICAL EXAMINAT	VILLALON, ARTURO 37	214	04/06/2017	04/10/2017		875.00

ALL RECORDS FROM 04/10/2017 TO 04/10/2017 DATE-TO-BE-PAID

VENDOR NAME	ACCOUNT #	ACCOUNT NAME	ITEM/REASON	INVOICE #	VP DATE	DATE TBP	PO NO	AMOUNT
PHILIP R TAFT PSY	2017 101-430-470	MEDICAL EXAMINAT	JOHNSON, DEMONTREY	215	04/06/2017	04/10/2017		2,975.00
POLYGRAPH SERVICES & IN	2017 101-435-475	INVESTIGATORS	WETZEL, GEORGE	3686 010617A	04/06/2017	04/10/2017		500.00
RANDALL BLACKWELL	2017 101-560-428	TRAVEL/CONFERENC	PICK UP 2013 TAHOE	REIMB - 04/0	04/06/2017	04/10/2017		76.50
REFRIGERATION HARDWARE	2017 101-512-445	REPAIRS & MAINT	OFFSET HANDLE LATCH	9Y6023	04/06/2017	04/10/2017	303820	38.24
REFRIGERATION HARDWARE	2017 101-512-445	REPAIRS & MAINT	STRIKE W/ADJUSTMENT	9Y6023	04/06/2017	04/10/2017	303820	10.22
REFRIGERATION HARDWARE	2017 101-512-445	REPAIRS & MAINT	SHIPPING	9Y6023	04/06/2017	04/10/2017	303820	16.19
RESERVE ACCOUNT	2017 101-406-311	POSTAGE	36909240 - POSTAGE	MAR 2017	04/04/2017	04/10/2017		5,000.00
ROBERT LOWELL THOMPSON	2017 101-475-428	TRAVEL/CONFERENC	PROSECUTING VIOLENT	APR 2017	04/05/2017	04/10/2017		206.51
ROBLES LAW FIRM	2017 101-435-411	COURT APPOINTED	DOUGLAS, DEKETRIC C	37203	04/06/2017	04/10/2017		700.00
ROBLES LAW FIRM	2017 101-425-411	COURT APPOINTED	YEPEZ, OSBALDO SERG	74124	04/06/2017	04/10/2017		200.00
ROBLES LAW FIRM	2017 101-425-411	COURT APPOINTED	YEPEZ, OSBALDO SERG	74125	04/06/2017	04/10/2017		100.00
ROBLES LAW FIRM	2017 101-435-411	COURT APPOINTED	NEW, TROY DON	37228	04/06/2017	04/10/2017		200.00
RYAN DOUGLAS	2017 101-497-428	TRAVEL/CONFERENC	45TH ANNUAL TREASUR	APR 2017	04/04/2017	04/10/2017		178.50
SANTA FE DISTRIBUTING I	2017 101-560-446	REPAIRS & MAINT	REPLACEMENT BLADE	00289626A	04/06/2017	04/10/2017	303796	44.92
SANTA FE DISTRIBUTING I	2017 101-560-446	REPAIRS & MAINT	REPLACEMENT DRILL B	00289626A	04/06/2017	04/10/2017	303796	9.59
SANTA FE DISTRIBUTING I	2017 101-560-446	REPAIRS & MAINT	SNAP GROMMET (100 P	00289626A	04/06/2017	04/10/2017	303796	4.97
SANTA FE DISTRIBUTING I	2017 101-560-446	REPAIRS & MAINT	1/2" WAFER HEAD SCR	00289626A	04/06/2017	04/10/2017	303796	5.50
SANTA FE DISTRIBUTING I	2017 101-560-446	REPAIRS & MAINT	3/4" WAFER HEAD SCR	00289626A	04/06/2017	04/10/2017	303796	5.51
SANTA FE DISTRIBUTING I	2017 101-560-446	REPAIRS & MAINT	LAIRD PORTABLE ANTE	00289626A	04/06/2017	04/10/2017	303796	41.34
SANTA FE DISTRIBUTING I	2017 101-560-446	REPAIRS & MAINT	SHIPPING	00289626A	04/06/2017	04/10/2017	303796	19.67
SANTA FE DISTRIBUTING I	2017 101-561-446	REPAIRS & MAINT	DOUBLE FEMALE ADAPT	00289626A	04/06/2017	04/10/2017	303796	4.86
SANTA FE DISTRIBUTING I	2017 101-561-446	REPAIRS & MAINT	MINI UHF CONNECTOR	00289626A	04/06/2017	04/10/2017	303796	4.52
SANTA FE DISTRIBUTING I	2017 101-561-446	REPAIRS & MAINT	RG-BX COAX	00289626A	04/06/2017	04/10/2017	303796	48.00
SHERIFF, PETTY CASH	2017 101-560-445	REPAIRS & MAINT	LOFTIS, CALEB	03/18/17	04/05/2017	04/10/2017		10.00
SHERIFF, PETTY CASH	2017 101-560-370	GAS & OIL	BLACKWELL, RANDALL	03/31/17	04/05/2017	04/10/2017		21.00
SHERIFF, PETTY CASH	2017 101-560-370	GAS & OIL	JOCK, ROBBIE	03/30/17	04/05/2017	04/10/2017		20.04
SHERIFF, PETTY CASH	2017 101-560-370	GAS & OIL	JOCK, ROBBIE	03/31/17	04/05/2017	04/10/2017		20.00
SHERIFF, PETTY CASH	2017 101-560-321	RESERVE FOR ENCU	JORDAN, CLITIS	04/03/17	04/05/2017	04/10/2017		10.00
SIGNATURE FLOORS AND MO	2017 101-512-445	REPAIRS & MAINT	REPAIRED MEN'S ADMI	2045	04/06/2017	04/10/2017	303391	1,508.06
SIGNATURE FLOORS AND MO	2017 101-512-445	REPAIRS & MAINT	REPAIRED WOMEN'S AD	2045	04/06/2017	04/10/2017	303391	1,508.06
SOLARWINDS, INC	2017 101-407-312	COMPUTER SUPPLIE	IP 1024 SOFTWARE MA	IN318903	04/05/2017	04/10/2017	303814	453.00
SPIT SHINE FLOORS	2017 101-410-459	MAINT CONTRACT -	VACUUMED CH & CLEAN	4265	04/06/2017	04/10/2017	303821	105.00
SPIT SHINE FLOORS	2017 101-410-459	MAINT CONTRACT -	CLEANED 1ST & 2ND F	4265	04/06/2017	04/10/2017	303821	90.00
SPIT SHINE FLOORS	2017 101-410-459	MAINT CONTRACT -	CLEANED COURTROOMS	4265	04/06/2017	04/10/2017	303821	48.00
SPIT SHINE FLOORS	2017 101-410-459	MAINT CONTRACT -	VACUUMED CH & CLEAN	4266	04/06/2017	04/10/2017	303879	105.00
SPIT SHINE FLOORS	2017 101-410-459	MAINT CONTRACT -	CLEANED 1ST & 2ND F	4266	04/06/2017	04/10/2017	303879	90.00
SPIT SHINE FLOORS	2017 101-410-459	MAINT CONTRACT -	CLEANED COURTROOMS	4266	04/06/2017	04/10/2017	303879	48.00
ST ANTHONY HOTEL	2017 101-499-428	TRAVEL/CONFERENC	2017 ACT USER CONF	DOWD, MIKE	04/05/2017	04/10/2017		282.53
ST ANTHONY HOTEL	2017 101-499-428	TRAVEL/CONFERENC	2017 ACT USER CONF	OWEN, JACKIE	04/05/2017	04/10/2017		282.53
SUPERCIRCUITS INC-TXMAS	2017 101-512-445	REPAIRS & MAINT	ALIBI 16CH RECORDER	9273911A	04/06/2017	04/10/2017	303760	476.39
SUPERCIRCUITS INC-TXMAS	2017 101-512-445	REPAIRS & MAINT	SHIPPING	9273911A	04/06/2017	04/10/2017	303760	21.60
SUSAN A WALDRIP COURT R	2017 101-435-412	TRANSCRIPTS	23949	10869	04/06/2017	04/10/2017		590.00
SUSAN A WALDRIP COURT R	2017 101-425-412	COURT REPORTER	70346	10858	04/06/2017	04/10/2017		1,180.00
SUSAN A WALDRIP COURT R	2017 101-425-412	COURT REPORTER	18660, 73019	10859	04/06/2017	04/10/2017		590.00
SYSTEM ID WAREHOUSE	2017 101-475-310	OFFICE SUPPLIES	DATAMAX - O'NEIL 3.	521704970	04/06/2017	04/10/2017	303829	70.00
SYSTEM ID WAREHOUSE	2017 101-475-310	OFFICE SUPPLIES	SHIPPING	521704970	04/06/2017	04/10/2017	303829	8.18
TAX ASSESSOR-COLLECTORS	2017 101-499-428	TRAVEL/CONFERENC	PTEC COURSE #28 TRU	DOWD, MIKE	04/05/2017	04/10/2017		85.00
TAX ASSESSOR-COLLECTORS	2017 101-499-428	TRAVEL/CONFERENC	PTEC #8 ASSESSMENT	DOWD, MIKE	04/05/2017	04/10/2017		85.00
TESSCO	2017 101-560-445	REPAIRS & MAINT	SHIPPING	906264	04/06/2017	04/10/2017	303776	7.60
TESSCO	2017 101-560-445	REPAIRS & MAINT	CELL/PCS/GPS ANTENN	906264	04/06/2017	04/10/2017	303776	371.01
TESSCO	2017 101-561-446	REPAIRS & MAINT	100W ELEMEMENT	906264	04/06/2017	04/10/2017	303776	85.70
TEXAS ASSOC OF COUNTIES	2017 101-403-428	TRAVEL/CONFERENC	122ND CC & DC CONF	DOWD, SHERRY	04/04/2017	04/10/2017		200.00
TEXAS ASSOC OF COUNTIES	2017 101-459-428	TRAVEL/CONFERENC	2017 ANNUAL JPCA CO	HICKMAN, CON	04/05/2017	04/10/2017		200.00
TEXAS CHIEF DEPUTIES AS	2017 101-560-428	TRAVEL/CONFERENC	31ST ANNUAL CHIEF D	STEWART, MOR	04/04/2017	04/10/2017		225.00
TEXAS DISTRICT & COUNTY	2017 101-475-419	DUES & SUBSCRIPT	TDCAA DUES 05/01/17	WOLF, ANDREW	04/06/2017	04/10/2017		60.00

ALL RECORDS FROM 04/10/2017 TO 04/10/2017 DATE-TO-BE-PAID

VENDOR NAME	ACCOUNT #	ACCOUNT NAME	ITEM/REASON	INVOICE #	VP DATE	DATE TBP	PO NO	AMOUNT
TIDY TOILETS	2017 101-512-445	REPAIRS & MAINT	CLEANED GREASE TRAP	7308	04/07/2017	04/10/2017		632.50
TIM'S TIRES & WHEELS	2017 101-560-445	REPAIRS & MAINT	UNIT 2583 - MOUNTED	063004	04/05/2017	04/10/2017	303669	10.00
TIM'S TIRES & WHEELS	2017 101-560-445	REPAIRS & MAINT	UNIT 2581 - FLAT	063018	04/05/2017	04/10/2017	303669	10.00
TIM'S TIRES & WHEELS	2017 101-560-445	REPAIRS & MAINT	UNIT 2180 - INSPECT	062939	04/05/2017	04/10/2017	302476	7.00
TIM'S TIRES & WHEELS	2017 101-560-445	REPAIRS & MAINT	UNIT 2473 - INSPECT	063049	04/07/2017	04/10/2017		7.00
TOMMY PRYOR	2017 101-407-428	TRAVEL/CONFERENC	FEMA CYBERSECURITY	REIMB - 04/0	04/05/2017	04/10/2017		500.90
TROPHIES UNLIMITED	2017 101-560-426	UNIFORMS	NAME TAG - GRIGSBY,	15388	04/05/2017	04/10/2017	302492	7.00
TROPHIES UNLIMITED	2017 101-560-310	OFFICE SUPPLIES	NAME PLATE - KELLEY	15446	04/07/2017	04/10/2017		17.00
TROPHIES UNLIMITED	2017 101-560-310	OFFICE SUPPLIES	NAME PLATE - BLACKW	15446	04/07/2017	04/10/2017		17.00
ULINE	2017 101-560-340	INVESTIGATIVE /	BULL HORN	85605989	04/06/2017	04/10/2017	303853	159.00
ULINE	2017 101-560-340	INVESTIGATIVE /	SHIPPING	85605989	04/06/2017	04/10/2017	303853	14.16
ULINE	2017 101-568-321	MAINTENANCE SUPP	BULL HORN	85605989	04/06/2017	04/10/2017	303853	159.00
US POSTAL SERVICE	2017 101-421-311	POSTAGE	2000 STAMPS @ .49	03/27/17	04/04/2017	04/10/2017		980.00
WAYTEK, INC	2017 101-560-321	RESERVE FOR ENCU	12V OUTLET HOUSING	2473362	04/06/2017	04/10/2017	303810	27.20
WAYTEK, INC	2017 101-560-321	RESERVE FOR ENCU	1/4" HEAT SHRINK	2473362	04/06/2017	04/10/2017	303810	6.80
WAYTEK, INC	2017 101-560-321	RESERVE FOR ENCU	16GA WIRE - BLUE	2473362	04/06/2017	04/10/2017	303810	30.40
WAYTEK, INC	2017 101-560-321	RESERVE FOR ENCU	CAP FOR HOUSING (10	2473362	04/06/2017	04/10/2017	303810	3.96
WAYTEK, INC	2017 101-560-321	RESERVE FOR ENCU	3/4" HOLE PLUG (12)	2473362	04/06/2017	04/10/2017	303810	5.94
WAYTEK, INC	2017 101-560-321	RESERVE FOR ENCU	SHIPPING	2473362	04/06/2017	04/10/2017	303810	19.42
WEATHER RADAR WARNING S	2017 101-568-453	CORAD	YEARLY - WEATHER RA	FY2017	04/07/2017	04/10/2017		5,000.00
WEST PUBLISHING CORP	2017 101-480-419	PUBLICATIONS	1000261004 01/01/17	0835533039	04/07/2017	04/10/2017		444.00
WILLIAM "ROBBIE" JOCK	2017 101-560-428	TRAVEL/CONFERENC	PICK UP 2013 TAHOE	REIMB - 04/0	04/06/2017	04/10/2017		76.50
WINTERS OIL COMPANY	2017 101-560-370	GAS & OIL	2400 GAL GAS	550019	04/07/2017	04/10/2017	303074	4,713.12
XEROX BUSINESS SERVICES	2017 101-403-410	PROFESSIONAL SER	289570 - MAR 2017	1358636	04/04/2017	04/10/2017		2,225.00
XEROX BUSINESS SERVICES	2017 101-403-310	OFFICE SUPPLIES	RECEIPT PAPER	1359245	04/05/2017	04/10/2017	303600	34.98
XEROX BUSINESS SERVICES	2017 101-403-310	OFFICE SUPPLIES	SHIPPING	1359245	04/05/2017	04/10/2017	303600	13.90
XEROX CORP - TXMAS	2017 101-425-440	COPIER RENTAL	656492824 - MAR	088255515	03/08/2017	04/10/2017		208.68
XEROX CORP - TXMAS	2017 101-497-440	COPIER RENTAL	715015608 - MAR	088255551	03/08/2017	04/10/2017		215.10
XEROX CORP - TXMAS	2017 101-499-440	COPIER RENTAL	711466284 - MAR	088255533	03/08/2017	04/10/2017		163.12
XEROX CORP - TXMAS	2017 101-499-310	OFFICE SUPPLIES	711466284 - MAR	088255533	03/08/2017	04/10/2017		6.19
XEROX CORP - TXMAS	2017 101-499-440	COPIER RENTAL	721386423 - MAR	088255590	03/08/2017	04/10/2017		148.38
XEROX CORP - TXMAS	2017 101-499-310	OFFICE SUPPLIES	721386423 - MAR	088255590	03/08/2017	04/10/2017		4.63
XEROX CORP - TXMAS	2017 101-475-440	COPIER RENTAL	723426839 - MAR	088255607	03/08/2017	04/10/2017		295.97
XEROX CORP - TXMAS	2017 101-475-440	COPIER RENTAL	723426847 - MAR	088255608	03/08/2017	04/10/2017		295.97
XEROX CORP - TXMAS	2017 101-403-440	COPIER RENTAL	723426045 - MAR	088255604	03/08/2017	04/10/2017		251.49
XEROX CORP - TXMAS	2017 101-403-440	COPIER RENTAL	721494623 - MAR	088255593	03/08/2017	04/10/2017		296.72
XEROX CORP - TXMAS	2017 101-403-440	COPIER RENTAL	721494623 - MAR	088371919	03/08/2017	04/10/2017		232.61
XEROX CORP - TXMAS	2017 101-430-440	COPIER RENTAL	723436853 - MAR	088255609	03/08/2017	04/10/2017		129.28
XEROX CORP - TXMAS	2017 101-430-310	OFFICE SUPPLIES	723436853 - MAR	088255609	03/08/2017	04/10/2017		.18
XEROX CORP - TXMAS	2017 101-497-440	COPIER RENTAL	712033315 - MAR	088255537	03/08/2017	04/10/2017		327.74
XEROX CORP - TXMAS	2017 101-497-310	OFFICE SUPPLIES	712033315 - MAR	088255537	03/08/2017	04/10/2017		19.74
XEROX CORP - TXMAS	2017 101-435-440	COPIER RENTAL	714267465 - MAR	088255548	03/08/2017	04/10/2017		152.20
XEROX CORP - TXMAS	2017 101-571-440	COPIER RENTAL	703607911 - MAR	088255516	03/08/2017	04/10/2017		369.89
XEROX CORP - TXMAS	2017 101-512-440	COPIER RENTAL	722543238 - MAR	088255596	03/08/2017	04/10/2017		177.51
XEROX CORP - TXMAS	2017 101-561-440	COPIER RENTAL	720050988 - MAR	088255580	03/08/2017	04/10/2017		184.00
XEROX CORP - TXMAS	2017 101-421-440	COPIER RENTAL	705177418 - MAR	088255521	03/08/2017	04/10/2017		385.67
XEROX CORP - TXMAS	2017 101-421-310	OFFICE SUPPLIES	705177418 - MAR	088255521	03/08/2017	04/10/2017		39.78
XEROX CORP - TXMAS	2017 101-401-440	COPIER RENTAL	704864040 - MAR	088255517	03/08/2017	04/10/2017		281.50
XEROX CORP - TXMAS	2017 101-401-310	OFFICE SUPPLIES	704864040 - MAR	088255517	03/08/2017	04/10/2017		16.96
XEROX CORP - TXMAS	2017 101-402-440	COPIER RENTAL	721389245 - MAR	088255591	03/08/2017	04/10/2017		258.84
XEROX CORP - TXMAS	2017 101-440-440	COPIER RENTAL	723426748 - APR	088640549	04/05/2017	04/10/2017		298.37
XEROX CORP - TXMAS	2017 101-430-310	OFFICE SUPPLIES	723436853 - APR	088640553	04/05/2017	04/10/2017		15.50
XEROX CORP - TXMAS	2017 101-430-440	COPIER RENTAL	723436853 - APR	088640553	04/05/2017	04/10/2017		129.28
XEROX CORP - TXMAS	2017 101-403-440	COPIER RENTAL	723426045 - APR	088640548	04/05/2017	04/10/2017		251.49
XEROX CORP - TXMAS	2017 101-475-440	COPIER RENTAL	723426847 - APR	088640552	04/05/2017	04/10/2017		295.97

ALL RECORDS FROM 04/10/2017 TO 04/10/2017 DATE-TO-BE-PAID

VENDOR NAME	ACCOUNT #	ACCOUNT NAME	ITEM/REASON	INVOICE #	VP DATE	DATE TBP	PO NO	AMOUNT
XEROX CORP - TXMAS	2017 101-475-440	COPIER RENTAL	723426839 - APR	088640551	04/05/2017	04/10/2017		295.97
XEROX CORP - TXMAS	2017 101-402-440	COPIER RENTAL	721389245 - APR	088640534	04/05/2017	04/10/2017		258.84
XEROX CORP - TXMAS	2017 101-499-440	COPIER RENTAL	721386423 - APR	088640533	04/05/2017	04/10/2017		148.38
XEROX CORP - TXMAS	2017 101-440-440	COPIER RENTAL	723426755 - APR	088640550	04/05/2017	04/10/2017		298.35
XEROX CORP - TXMAS	2017 101-571-440	COPIER RENTAL	705401511 - APR	088640453	04/06/2017	04/10/2017		379.29
XEROX CORP - TXMAS	2017 101-401-310	OFFICE SUPPLIES	704864040 - APR	088640451	04/06/2017	04/10/2017		17.76
XEROX CORP - TXMAS	2017 101-401-440	COPIER RENTAL	704864040 - APR	088640451	04/06/2017	04/10/2017		281.50
XEROX CORP - TXMAS	2017 101-560-440	COPIER RENTAL	713338473 - APR	088640475	04/06/2017	04/10/2017		226.30
XEROX CORP - TXMAS	2017 101-435-440	COPIER RENTAL	714267465 - APR	088640485	04/06/2017	04/10/2017		152.20
XEROX CORP - TXMAS	2017 101-497-310	OFFICE SUPPLIES	712033315 - APR	088640471	04/06/2017	04/10/2017		10.76
XEROX CORP - TXMAS	2017 101-497-440	COPIER RENTAL	712033315 - APR	088640471	04/06/2017	04/10/2017		327.74
XEROX CORP - TXMAS	2017 101-409-440	COPIER RENTAL	715015608 - APR	088640489	04/06/2017	04/10/2017		215.10
XEROX CORP - TXMAS	2017 101-561-440	COPIER RENTAL	720050988 - APR	088640522	04/06/2017	04/10/2017		184.00
XEROX CORP - TXMAS	2017 101-421-310	OFFICE SUPPLIES	705177418 - APR	088640452	04/06/2017	04/10/2017		46.13
XEROX CORP - TXMAS	2017 101-421-440	COPIER RENTAL	705177418 - APR	088640452	04/06/2017	04/10/2017		385.67
XEROX CORP - TXMAS	2017 101-571-440	COPIER RENTAL	703607911 - APR	088640450	04/06/2017	04/10/2017		369.89
XEROX CORP - TXMAS	2017 101-512-440	COPIER RENTAL	722543238 - APR	088640542	04/06/2017	04/10/2017		177.51
XEROX CORP - TXMAS	2017 101-402-440	COPIER RENTAL	721466365 - APR	088640535	04/06/2017	04/10/2017		309.18
XEROX CORP - TXMAS	2017 101-403-440	COPIER RENTAL	721494623 - APR	088640539	04/06/2017	04/10/2017		232.61
XEROX CORP - TXMAS	2017 101-403-440	COPIER RENTAL	721494623 - APR	088640538	04/06/2017	04/10/2017		296.72
XEROX CORP - TXMAS	2017 101-499-310	OFFICE SUPPLIES	711466284 - APR	088640466	04/06/2017	04/10/2017		2.55
XEROX CORP - TXMAS	2017 101-499-440	COPIER RENTAL	711466284 - APR	088640466	04/06/2017	04/10/2017		163.12
XEROX CORP - TXMAS	2017 101-425-440	COPIER RENTAL	656492824 - APR	088640449	04/06/2017	04/10/2017		208.68
XEROX CORP - TXMAS	2017 101-572-440	COPIER RENTAL	723003380 - MAR	088450719	04/06/2017	04/10/2017		151.78
XEROX CORP - TXMAS	2017 101-572-310	OFFICE SUPPLIES	723003380 - MAR	088450719	04/06/2017	04/10/2017		52.35
XEROX CORP - TXMAS	2017 101-495-440	COPIER RENTAL	721466431 - MAR	088489222	04/07/2017	04/10/2017		463.75
XEROX CORP - TXMAS	2017 101-495-310	OFFICE SUPPLIES	721466431 - APR	088640536	04/07/2017	04/10/2017		45.33

 177,638.32

ALL RECORDS FROM 04/10/2017 TO 04/10/2017 DATE-TO-BE-PAID

VENDOR NAME	ACCOUNT #	ACCOUNT NAME	ITEM/REASON	INVOICE #	VP DATE	DATE TBP	PO NO	AMOUNT
LINDA F YOUNG LCSW LSOT	2017 151-573-410	CONTRACT SERVICE	SEX OFFENDER TREATM	03/29/17	04/06/2017	04/10/2017		720.00
LINDA F YOUNG LCSW LSOT	2017 151-573-410	CONTRACT SERVICE	SEX OFFENDER TREATM	03/29/17	04/06/2017	04/10/2017		187.50
THEDFORD OFFICE SUPPLY	2017 151-571-310	DEPARTMENT SUPPL	DELL B2375DNF TONER	28381	04/06/2017	04/10/2017	303836	89.99
VALVOLINE EXPRESS CARE	2017 151-571-370	GAS. OIL & REPAI	2009 TAHOE - OIL CH	184119	04/06/2017	04/10/2017	303875	46.68
VALVOLINE EXPRESS CARE	2017 151-571-370	GAS. OIL & REPAI	2009 TAHOE - WIPER	184119	04/06/2017	04/10/2017	303875	33.98
XEROX CORP - TXMAS	2017 151-571-310	DEPARTMENT SUPPL	703607911 - MAR	088255516	03/08/2017	04/10/2017		13.04
XEROX CORP - TXMAS	2017 151-571-310	DEPARTMENT SUPPL	705401511 - APR	088640453	04/06/2017	04/10/2017		37.85

								1,129.04

ALL RECORDS FROM 04/10/2017 TO 04/10/2017 DATE-TO-BE-PAID

VENDOR NAME	ACCOUNT #	ACCOUNT NAME	ITEM/REASON	INVOICE #	VP DATE	DATE TBP	PO NO	AMOUNT
NORMAN LEE STUBBS	2017 161-573-576	CAPITAL IMPROVEM	315 W 3RD - MATERIA	075530	04/06/2017	04/10/2017	303870	1,885.00
								----- 1,885.00

ALL RECORDS FROM 04/10/2017 TO 04/10/2017 DATE-TO-BE-PAID

VENDOR NAME	ACCOUNT #	ACCOUNT NAME	ITEM/REASON	INVOICE #	VP DATE	DATE TBP	PO NO	AMOUNT
AT&T SERVICES INC.	2017 211-611-435	TELEPHONE	287236363034 02/20/	3034 - MAR 2	04/04/2017	04/10/2017		53.04
ATWOODS DISTRIBUTING LP	2017 211-611-426	UNIFORMS	GLOVES	2989/37	04/06/2017	04/10/2017	302496	39.96
ATWOODS DISTRIBUTING LP	2017 211-611-330	JANITORIAL SUPPL	PINE SOL	2989/37	04/06/2017	04/10/2017	302496	7.98
ATWOODS DISTRIBUTING LP	2017 211-611-321	MAINTENANCE SUPP	1" DIESEL FUEL NOZZ	3022/37	04/06/2017	04/10/2017	302496	99.99
ATWOODS DISTRIBUTING LP	2017 211-611-324	BLADES	BLADE	2990/37	04/06/2017	04/10/2017	302496	17.99
B & B WATER SUPPLY	2017 211-611-430	UTILITIES	4201 HWY 22 02/22/1	262 - MAR 20	04/06/2017	04/10/2017		52.60
BIG H TIRE SERVICE	2017 211-611-445	REPAIRS & MAINT	UNIT 310 - MOUNTED	164235	04/06/2017	04/10/2017	303785	133.50
CITY OF CORSICANA	2017 211-611-495	MISCELLANEOUS	NW0080 - BRUSH	300630	04/06/2017	04/10/2017		23.70
GILFILLAN HARDWARE	2017 211-611-321	MAINTENANCE SUPP	GALV PLUGS	78290/1	04/06/2017	04/10/2017	302500	3.50
GILFILLAN HARDWARE	2017 211-611-321	MAINTENANCE SUPP	PVC PRIMER, PVC CEM	79127/1	04/06/2017	04/10/2017	302521	18.27
GILFILLAN HARDWARE	2017 211-611-321	MAINTENANCE SUPP	PVC ADAPTER, PVC PI	79127/1	04/06/2017	04/10/2017	302521	1.73
HILLTOP SAND & GRAVEL	2017 211-611-376	ROAD MATERIAL	NE2060, NW1210, YAR	16405	04/07/2017	04/10/2017	303563	1,511.91
HILLTOP SAND & GRAVEL	2017 211-611-453	HAULING	NE2060, NW1210, YAR	16405	04/07/2017	04/10/2017	303563	1,075.14
HUFFMAN COMMUNICATIONS	2017 211-611-450	MAINT CONTRACT	MAINTENANCE AGREEME	46746	04/07/2017	04/10/2017		41.13
NAVARRO COUNTY ELECTRIC	2017 211-611-430	UTILITIES	13138301 - 4201 HWY	8301 - MAR 2	04/07/2017	04/10/2017		67.93
PROSPERITY BANK #107155	2017 211-611-573	CAPITAL LEASE PR	LOAN #1071550	APR 2017	04/07/2017	04/10/2017		3,302.67
PROSPERITY BANK #107155	2017 211-611-574	CAPITAL LEASE IN	LOAN #1071550	APR 2017	04/07/2017	04/10/2017		282.67
PROSPERITY BANK #107244	2017 211-611-573	CAPITAL LEASE PR	LOAN #1072444	APR 2017	04/07/2017	04/10/2017		2,173.06
PROSPERITY BANK #107244	2017 211-611-574	CAPITAL LEASE IN	LOAN #1072444	APR 2017	04/07/2017	04/10/2017		181.26
PURVIS INDUSTRIES LTD	2017 211-611-321	MAINTENANCE SUPP	UNIT 15 - HYDRAULIC	7423511	04/07/2017	04/10/2017	302504	37.22
RATTLER ROCK INC	2017 211-611-376	ROAD MATERIAL	NE1100	118092	04/07/2017	04/10/2017	302508	270.77
RATTLER ROCK INC	2017 211-611-376	ROAD MATERIAL	NE1040, NW1041, YAR	118106	04/07/2017	04/10/2017	302508	800.33
RATTLER ROCK INC	2017 211-611-376	ROAD MATERIAL	NE2050	118135	04/07/2017	04/10/2017	302508	546.33
RATTLER ROCK INC	2017 211-611-376	ROAD MATERIAL	YARD	118175	04/07/2017	04/10/2017	302508	798.34
RATTLER ROCK INC	2017 211-611-376	ROAD MATERIAL	YARD	118191	04/07/2017	04/10/2017	302508	809.88
RATTLER ROCK INC	2017 211-611-376	ROAD MATERIAL	NW0140, NE2050	118207	04/07/2017	04/10/2017	302508	805.71
RATTLER ROCK INC	2017 211-611-376	ROAD MATERIAL	NW0140, YARD	118239	04/07/2017	04/10/2017	302508	801.53
RATTLER ROCK INC	2017 211-611-376	ROAD MATERIAL	NE0190, YARD	118258	04/07/2017	04/10/2017	302508	798.01
RATTLER ROCK INC	2017 211-611-376	ROAD MATERIAL	NE1050, NE3260	118275	04/07/2017	04/10/2017	302508	821.39
RATTLER ROCK INC	2017 211-611-376	ROAD MATERIAL	NE0190	118296	04/07/2017	04/10/2017	302508	822.65
RATTLER ROCK INC	2017 211-611-376	ROAD MATERIAL	NE0240	118314	04/07/2017	04/10/2017	302508	812.31
RATTLER ROCK INC	2017 211-611-376	ROAD MATERIAL	NE0260, NE1045	118334	04/07/2017	04/10/2017	302508	544.95
RATTLER ROCK INC	2017 211-611-376	ROAD MATERIAL	YARD	118372	04/07/2017	04/10/2017	302508	1,090.12
RATTLER ROCK INC	2017 211-611-376	ROAD MATERIAL	YARD	118387	04/07/2017	04/10/2017	302508	809.68
RATTLER ROCK INC	2017 211-611-376	ROAD MATERIAL	YARD	118410	04/07/2017	04/10/2017	302508	803.39
RATTLER ROCK INC	2017 211-611-376	ROAD MATERIAL	YARD	118456	04/07/2017	04/10/2017	302508	800.31
RATTLER ROCK INC	2017 211-611-376	ROAD MATERIAL	YARD	118476	04/07/2017	04/10/2017	302508	814.34
RATTLER ROCK INC	2017 211-611-376	ROAD MATERIAL	NE0130, YARD	118503	04/07/2017	04/10/2017	302508	805.99
RATTLER ROCK INC	2017 211-611-376	ROAD MATERIAL	NE0130	118520	04/07/2017	04/10/2017	302508	531.91
REPUBLIC SERVICES #069	2017 211-611-430	UTILITIES	3-0069-0052829 - MA	0069-0008584	04/07/2017	04/10/2017		165.47
TEXAS BIT	2017 211-611-376	ROAD MATERIAL	NW0009	200566783	04/07/2017	04/10/2017	302510	1,185.10
TEXAS BIT	2017 211-611-376	ROAD MATERIAL	ASPHALT CR POTHOLES	200567179	04/07/2017	04/10/2017	302510	718.50
TIMCO BLASTING & COATIN	2017 211-611-453	HAULING	NE1100, NW1041, NE1	016896	04/07/2017	04/10/2017	302514	11,290.88
TIMCO BLASTING & COATIN	2017 211-611-453	HAULING	NE0190, NE3260, NE0	016894	04/07/2017	04/10/2017	302514	14,778.13
UNITED RENTALS INC - TX	2017 211-611-448	MACHINE HIRE	RENTED ROLLER 50-56	145053071-00	04/07/2017	04/10/2017	303805	674.80
WELCH STATE BANK	2017 211-611-573	CAPITAL LEASE PR	LEASE NO 51583	APR 2017	04/07/2017	04/10/2017		2,195.39
WELCH STATE BANK	2017 211-611-574	CAPITAL LEASE IN	LEASE NO 51583	APR 2017	04/07/2017	04/10/2017		130.39
WINTERS OIL COMPANY	2017 211-611-370	GAS & OIL	200 GAL GAS	549863	04/06/2017	04/10/2017	303827	372.60
WINTERS OIL COMPANY	2017 211-611-370	GAS & OIL	2000 GAL GAS	549863	04/06/2017	04/10/2017	303827	3,780.00

58,704.45

ALL RECORDS FROM 04/10/2017 TO 04/10/2017 DATE-TO-BE-PAID

VENDOR NAME	ACCOUNT #	ACCOUNT NAME	ITEM/REASON	INVOICE #	VP DATE	DATE TBP	PO NO	AMOUNT
A PLUS CYLINDER HEADS L	2017 212-612-445	REPAIRS & MAINTENANCE	UNIT 24 - REPLACED	184862	04/06/2017	04/10/2017	303843	1,015.00
ATWOODS DISTRIBUTING LP	2017 212-612-335	YARD MAINTENANCE	25 GAL WEED SPOT SP	3026/37	04/06/2017	04/10/2017	303923	119.99
ATWOODS DISTRIBUTING LP	2017 212-612-321	MAINTENANCE SUPP	30 GAL DEF	3008/37	04/06/2017	04/10/2017	302515	83.88
B & G AUTO PARTS	2017 212-612-321	MAINTENANCE SUPP	24T - INJECTORS	613699	04/06/2017	04/10/2017	303828	1,425.00
B & G AUTO PARTS	2017 212-612-321	MAINTENANCE SUPP	UNIT 233 - WATER PU	613783	04/06/2017	04/10/2017	303873	45.50
B & G AUTO PARTS	2017 212-612-321	MAINTENANCE SUPP	UNIT 233 - FUEL FIL	613783	04/06/2017	04/10/2017	303873	13.80
B & G AUTO PARTS	2017 212-612-321	MAINTENANCE SUPP	UNIT 233 - FUEL FIL	613783	04/06/2017	04/10/2017	303873	10.50
B & G AUTO PARTS	2017 212-612-321	MAINTENANCE SUPP	UNIT 233 - FUEL FIL	613783	04/06/2017	04/10/2017	303873	4.90
B & G AUTO PARTS	2017 212-612-321	MAINTENANCE SUPP	UNIT 233 - AIR FILT	613783	04/06/2017	04/10/2017	303873	45.50
B & G AUTO PARTS	2017 212-612-321	MAINTENANCE SUPP	UNIT 233 - AIR FILT	613783	04/06/2017	04/10/2017	303873	101.90
B & G AUTO PARTS	2017 212-612-321	MAINTENANCE SUPP	UNIT 233 - RADIATOR	613783	04/06/2017	04/10/2017	303873	5.35
B & G AUTO PARTS	2017 212-612-321	MAINTENANCE SUPP	ANTIFREEZE	613784	04/06/2017	04/10/2017	302516	71.70
B & G AUTO PARTS	2017 212-612-321	MAINTENANCE SUPP	UNIT 24 - FUEL FILT	613738	04/06/2017	04/10/2017	302516	21.50
B & G AUTO PARTS	2017 212-612-321	MAINTENANCE SUPP	UNIT 233 - OIL FILT	613792	04/06/2017	04/10/2017	302516	10.00
B & G AUTO PARTS	2017 212-612-321	MAINTENANCE SUPP	HOSE, TOGGLE SWITCH	613831	04/06/2017	04/10/2017	302516	12.60
B & G AUTO PARTS	2017 212-612-321	MAINTENANCE SUPP	UNIT 24T - RELAY	613772	04/06/2017	04/10/2017	302516	24.85
B & G AUTO PARTS	2017 212-612-321	MAINTENANCE SUPP	UNIT 200 - AIR FILT	613756	04/06/2017	04/10/2017	302516	33.00
CITY OF KERENS	2017 212-612-430	UTILITIES	907 NW SECOND	1205 - MAR 2	04/06/2017	04/10/2017		75.75
DICK MARTIN	2017 212-612-445	REPAIRS & MAINTENANCE	REGISTRATION - 1GCD	03/30/17	04/07/2017	04/10/2017	303869	7.50
FOOD RITE INC	2017 212-612-330	JANITORIAL SUPPL	PINE GLEAM CLEANER,	0140 - 03/07	04/06/2017	04/10/2017	302520	8.65
FOOD RITE INC	2017 212-612-330	JANITORIAL SUPPL	MOP & SHINE, GLADE,	0140 - 03/07	04/06/2017	04/10/2017	302520	6.58
GILFILLAN HARDWARE	2017 212-612-321	MAINTENANCE SUPP	SLEDGE HAMMER	79010/1	04/06/2017	04/10/2017	302521	35.99
GILFILLAN HARDWARE	2017 212-612-321	MAINTENANCE SUPP	GALV ELBOW, SEAL TA	79428/1	04/06/2017	04/10/2017	302521	6.08
GILFILLAN HARDWARE	2017 212-612-321	MAINTENANCE SUPP	AAA BATTERIES	79430/1	04/06/2017	04/10/2017	302521	23.98
GILFILLAN HARDWARE	2017 212-612-321	MAINTENANCE SUPP	300' FLAG TAPE	79727/1	04/06/2017	04/10/2017	302521	7.47
HOLT CAT	2017 212-612-445	REPAIRS & MAINTENANCE	MOTOR GRADER - REPL	WIM00068404	04/07/2017	04/10/2017		1,915.36
HOLT CAT	2017 212-612-445	REPAIRS & MAINTENANCE	MOTOR GRADER - LABO	WIM00068404	04/07/2017	04/10/2017		1,155.50
HOLT CAT	2017 212-612-445	REPAIRS & MAINTENANCE	MOTOR GRADER - DISC	WIM00068404	04/07/2017	04/10/2017		2,453.90-
HUFFMAN COMMUNICATIONS	2017 212-612-450	MAINT CONTRACT	MAINTENANCE AGREEME	46748	04/07/2017	04/10/2017		41.12
K & S TIRE TOWING & REC	2017 212-612-445	REPAIRS & MAINTENANCE	UNIT 226 - INSPECTI	65775	04/07/2017	04/10/2017	302523	7.00
KERENS GRAIN & ELEVATOR	2017 212-612-335	YARD MAINTENANCE	2 5 GAL WEED KILLER	137165	04/07/2017	04/10/2017		91.30
KIRBY SMITH MACHINERY I	2017 212-612-321	MAINTENANCE SUPP	UNIT 200 - HYDRAULI	P21408	04/06/2017	04/10/2017	303877	392.50
MARTIN MARIETTA MATERIA	2017 212-612-376	ROAD MATERIAL	ASP, SE0070, NE2120	19964704	04/07/2017	04/10/2017	302575	3,848.63
MARTIN MARIETTA MATERIA	2017 212-612-376	ROAD MATERIAL	NE2010, NE3030, NE3	19909502	04/07/2017	04/10/2017	302575	4,001.46
MARTIN MARIETTA MATERIA	2017 212-612-376	ROAD MATERIAL	NE3012	19882212	04/07/2017	04/10/2017	302575	2,124.49
MARTIN MARIETTA MATERIA	2017 212-612-376	ROAD MATERIAL	NE3011, NE3030, SE0	19932813	04/07/2017	04/10/2017	302575	5,464.31
MCCOY'S BUILDING SUPPLY	2017 212-612-495	MISCELLANEOUS	STAKE FLAGS - WHITE	5913214	04/07/2017	04/10/2017	303524	15.36
MCCOY'S BUILDING SUPPLY	2017 212-612-376	ROAD MATERIAL	BLACKTOP PATCH	5912685	04/07/2017	04/10/2017		134.13
MCCOY'S BUILDING SUPPLY	2017 212-612-376	ROAD MATERIAL	REFERENCE TO INV 59	5912688	04/07/2017	04/10/2017		134.13-
O'REILLY AUTOMOTIVE STO	2017 212-612-321	MAINTENANCE SUPP	UNIT 24 - FUEL PUMP	0763-122201	04/06/2017	04/10/2017	303862	221.55
O'REILLY AUTOMOTIVE STO	2017 212-612-321	MAINTENANCE SUPP	UNIT 24 - ADAPTER	0763-119915	04/07/2017	04/10/2017	302525	19.99
O'REILLY AUTOMOTIVE STO	2017 212-612-321	MAINTENANCE SUPP	HEADLIGHT BULB, GLA	0763-122208	04/07/2017	04/10/2017	302525	34.47
O'REILLY AUTOMOTIVE STO	2017 212-612-370	GAS & OIL	DIESEL ADDITIVES	0763-121258	04/07/2017	04/10/2017	302525	47.47
O'REILLY AUTOMOTIVE STO	2017 212-612-321	MAINTENANCE SUPP	ANTIFREEZE	0763-121258	04/07/2017	04/10/2017	302525	19.12
OLANDER DONALDSON	2017 212-612-495	MISCELLANEOUS	CDL RENEWAL - DONAL	REIMB 04/06/	04/06/2017	04/10/2017		61.00
OWEN HARDWARE INC	2017 212-612-321	MAINTENANCE SUPP	HOSE BARB INSERT FI	AA59713	04/07/2017	04/10/2017	302526	11.97
PHILLIPS TIRE	2017 212-612-445	REPAIRS & MAINTENANCE	UNIT 28 - PATCH	282	04/07/2017	04/10/2017	302527	12.00
PHOENIX EXCHANGE INC	2017 212-612-445	REPAIRS & MAINTENANCE	UNIT 200 - REBUILT	76018	04/06/2017	04/10/2017	303824	613.00
PURVIS INDUSTRIES LTD	2017 212-612-321	MAINTENANCE SUPP	HYDRAULIC HOSE	7422892	04/07/2017	04/10/2017	302528	41.36
TEXAS BIT	2017 212-612-376	ROAD MATERIAL	SE3121, SE3122	200568056	04/07/2017	04/10/2017	302576	886.90
TEXAS BIT	2017 212-612-376	ROAD MATERIAL	SE3122	200567657	04/07/2017	04/10/2017	302576	6,316.56
TRUCK PARTS & SERVICE I	2017 212-612-321	MAINTENANCE SUPP	UNIT 209 - HEATER C	27571	04/06/2017	04/10/2017	303928	274.58
TRUCK PARTS & SERVICE I	2017 212-612-321	MAINTENANCE SUPP	FITTING	27416	04/07/2017	04/10/2017	302531	3.19
TRUCK PARTS & SERVICE I	2017 212-612-321	MAINTENANCE SUPP	UNIT 214 - OUTER NU	27415	04/07/2017	04/10/2017	302531	81.60
TRUCK PARTS & SERVICE I	2017 212-612-321	MAINTENANCE SUPP	PRESSURE WASHER W/M	27542	04/07/2017	04/10/2017	302531	69.39

ALL RECORDS FROM 04/10/2017 TO 04/10/2017 DATE-TO-BE-PAID

VENDOR NAME	ACCOUNT #	ACCOUNT NAME	ITEM/REASON	INVOICE #	VP DATE	DATE TBP	PO NO	AMOUNT
A-I HOGAN HYDRAULICS	2017 213-613-445	REPAIRS & MAINT	UNIT 308 - REBUILT	013848	04/06/2017	04/10/2017	303831	400.00
ATWOODS DISTRIBUTING LP	2017 213-613-321	MAINTENANCE SUPP	UNIT 304 - TRACTOR	3010/37	04/06/2017	04/10/2017	302532	31.98
ATWOODS DISTRIBUTING LP	2017 213-613-321	MAINTENANCE SUPP	UNIT 308 - TRACTOR	3010/37	04/06/2017	04/10/2017	302532	31.98
BIG H TIRE SERVICE	2017 213-613-445	REPAIRS & MAINT	UNIT 305 - FLAT	164306	04/06/2017	04/10/2017	302534	50.00
BIG H TIRE SERVICE	2017 213-613-445	REPAIRS & MAINT	UNIT 304 - FLAT	164363	04/06/2017	04/10/2017	302534	50.00
BIG H TIRE SERVICE	2017 213-613-445	REPAIRS & MAINT	UNIT 316 - FLAT	164363	04/06/2017	04/10/2017	302534	25.00
BIG H TIRE SERVICE	2017 213-613-445	REPAIRS & MAINT	UNIT 315 - FLAT	164363	04/06/2017	04/10/2017	302534	25.00
CITY OF DAWSON	2017 213-613-430	UTILITIES	17500 FM 709	324 - MAR 20	04/06/2017	04/10/2017		39.80
CORSICANA NAPA AUTO PAR	2017 213-613-321	MAINTENANCE SUPP	UNIT 316 - LUBE FIL	064978	04/06/2017	04/10/2017	303846	16.82
CORSICANA NAPA AUTO PAR	2017 213-613-321	MAINTENANCE SUPP	UNIT 316 - FUEL FIL	064978	04/06/2017	04/10/2017	303846	59.12
CORSICANA NAPA AUTO PAR	2017 213-613-321	MAINTENANCE SUPP	UNIT 315 - FUEL FIL	064978	04/06/2017	04/10/2017	303846	22.85
CORSICANA NAPA AUTO PAR	2017 213-613-321	MAINTENANCE SUPP	UNIT 308 - FUEL FIL	064978	04/06/2017	04/10/2017	303846	46.78
CORSICANA NAPA AUTO PAR	2017 213-613-321	MAINTENANCE SUPP	UNIT 316 - AIR FILT	064978	04/06/2017	04/10/2017	303846	82.02
CORSICANA NAPA AUTO PAR	2017 213-613-321	MAINTENANCE SUPP	UNIT 315 - AIR FILT	064978	04/06/2017	04/10/2017	303846	48.49
CORSICANA NAPA AUTO PAR	2017 213-613-321	MAINTENANCE SUPP	UNIT 308 - AIR FILT	064978	04/06/2017	04/10/2017	303846	48.49
CORSICANA NAPA AUTO PAR	2017 213-613-321	MAINTENANCE SUPP	UNIT 316 - HYDRAULI	064978	04/06/2017	04/10/2017	303846	69.46
CORSICANA NAPA AUTO PAR	2017 213-613-321	MAINTENANCE SUPP	UNIT 315 - HYDRAULI	064978	04/06/2017	04/10/2017	303846	134.02
CORSICANA NAPA AUTO PAR	2017 213-613-321	MAINTENANCE SUPP	UNIT 308 - HYDRAULI	064978	04/06/2017	04/10/2017	303846	55.37
CORSICANA NAPA AUTO PAR	2017 213-613-321	MAINTENANCE SUPP	UNIT 316 - OIL FILT	064978	04/06/2017	04/10/2017	303846	24.56
CORSICANA NAPA AUTO PAR	2017 213-613-321	MAINTENANCE SUPP	5 GAL HYDRAULIC FLU	064978	04/06/2017	04/10/2017	303846	65.18
CORSICANA NAPA AUTO PAR	2017 213-613-321	MAINTENANCE SUPP	WOODEN HANDLE	064978	04/06/2017	04/10/2017	303846	6.99
CORSICANA NAPA AUTO PAR	2017 213-613-321	MAINTENANCE SUPP	10" BRUSH HEAD	064978	04/06/2017	04/10/2017	303846	11.99
CORSICANA NAPA AUTO PAR	2017 213-613-321	MAINTENANCE SUPP	2005 FORD - BATTERI	064978	04/06/2017	04/10/2017	303846	281.38
CORSICANA NAPA AUTO PAR	2017 213-613-321	MAINTENANCE SUPP	UNIT 315 - OIL FILT	064978	04/06/2017	04/10/2017	303846	17.38
ECONO SIGNS LLC	2017 213-613-322	SIGN SUPPLIES	18" X 24" NO THRU T	10-935011	04/06/2017	04/10/2017	303547	59.34
ECONO SIGNS LLC	2017 213-613-322	SIGN SUPPLIES	18" X 6" BLANK DOUB	10-935011	04/06/2017	04/10/2017	303547	169.60
ECONO SIGNS LLC	2017 213-613-322	SIGN SUPPLIES	4" WHITE "4"	10-935011	04/06/2017	04/10/2017	303547	38.43
ECONO SIGNS LLC	2017 213-613-322	SIGN SUPPLIES	4" WHITE "1"	10-935011	04/06/2017	04/10/2017	303547	38.43
ECONO SIGNS LLC	2017 213-613-322	SIGN SUPPLIES	4" WHITE "0"	10-935011	04/06/2017	04/10/2017	303547	51.24
ECONO SIGNS LLC	2017 213-613-322	SIGN SUPPLIES	4" WHITE "S"	10-935011	04/06/2017	04/10/2017	303547	51.24
ECONO SIGNS LLC	2017 213-613-322	SIGN SUPPLIES	4" WHITE "W"	10-935011	04/06/2017	04/10/2017	303547	51.24
ECONO SIGNS LLC	2017 213-613-322	SIGN SUPPLIES	SHIPPING	10-935011	04/06/2017	04/10/2017	303547	44.18
HILLTOP SAND & GRAVEL	2017 213-613-376	ROAD MATERIAL	SW0030, SW4310, SW4	16406	04/07/2017	04/10/2017	303567	21,468.42
HILLTOP SAND & GRAVEL	2017 213-613-453	HAULING	SW0030, SW4310, SW4	16406	04/07/2017	04/10/2017	303567	15,266.43
HUFFMAN COMMUNICATIONS	2017 213-613-450	MAINT CONTRACT	MAINTENANCE AGREEME	46747	04/07/2017	04/10/2017		41.12
KEITH'S ACE HARDWARE	2017 213-613-321	MAINTENANCE SUPP	1/4" DRILL BIT	46953	04/07/2017	04/10/2017	302541	6.99
KNIFE RIVER CORPORTATIO	2017 213-613-376	ROAD MATERIAL	SW4040	572722	04/07/2017	04/10/2017	302585	195.28
KNIFE RIVER CORPORTATIO	2017 213-613-376	ROAD MATERIAL	RSP	572325	04/07/2017	04/10/2017	302585	585.58
KNIFE RIVER CORPORTATIO	2017 213-613-376	ROAD MATERIAL	SW2383, SW2250	571696	04/07/2017	04/10/2017	302585	1,185.86
KNIFE RIVER CORPORTATIO	2017 213-613-376	ROAD MATERIAL	SW2250, RSP	571479	04/07/2017	04/10/2017	302585	1,188.09
KNIFE RIVER CORPORTATIO	2017 213-613-376	ROAD MATERIAL	YOUTH EXPO, SE2250,	572081	04/07/2017	04/10/2017	302585	1,900.16
KNIFE RIVER CORPORTATIO	2017 213-613-376	ROAD MATERIAL	SW4250, SW4260, SW0	569307	04/07/2017	04/10/2017	302585	1,184.80
KNIFE RIVER CORPORTATIO	2017 213-613-376	ROAD MATERIAL	SW4220, SW0010, RSP	570149	04/07/2017	04/10/2017	302585	1,172.67
KNIFE RIVER CORPORTATIO	2017 213-613-376	ROAD MATERIAL	SW4260	569749	04/07/2017	04/10/2017	302585	776.24
KNIFE RIVER CORPORTATIO	2017 213-613-376	ROAD MATERIAL	SE4260, SW2250	570446	04/07/2017	04/10/2017	302585	571.73
LEGACY BULK TRUCKING CO	2017 213-613-453	HAULING	NW3230, NW3240, NW4	1267	04/07/2017	04/10/2017	303405	1,937.66
LEGACY BULK TRUCKING CO	2017 213-613-453	HAULING	NW3220, NW3230, NW3	1266	04/07/2017	04/10/2017	303405	1,392.18
MCCOY'S BUILDING SUPPLY	2017 213-613-376	ROAD MATERIAL	REFERENCE TO INV 59	5912755	04/07/2017	04/10/2017	303601	20.00-
MCCOY'S BUILDING SUPPLY	2017 213-613-376	ROAD MATERIAL	CONCRETE PALLET	5912759	04/07/2017	04/10/2017	303601	20.00
MILLS AUTO SUPPLY	2017 213-613-321	MAINTENANCE SUPP	NOSE PLIERS, SCREWD	12JC4437	04/07/2017	04/10/2017	302546	19.07
MILLS AUTO SUPPLY	2017 213-613-330	JANITORIAL SUPPL	SHOP TOWELS, HAND C	12JC4437	04/07/2017	04/10/2017	302546	15.06
NORTHEAST TEXAS WATER S	2017 213-613-430	UTILITIES	00300419 02/28/17 -	0419 - APR 2	04/07/2017	04/10/2017		37.46
O'REILLY AUTOMOTIVE STO	2017 213-613-321	MAINTENANCE SUPP	UNIT 315 - OIL FILT	0763-122179	04/06/2017	04/10/2017	303861	10.43
O'REILLY AUTOMOTIVE STO	2017 213-613-321	MAINTENANCE SUPP	UNIT 316 - OIL FILT	0763-122179	04/06/2017	04/10/2017	303861	10.43
O'REILLY AUTOMOTIVE STO	2017 213-613-321	MAINTENANCE SUPP	UNIT 315 - AIR FILT	0763-122179	04/06/2017	04/10/2017	303861	69.71

ALL RECORDS FROM 04/10/2017 TO 04/10/2017 DATE-TO-BE-PAID

VENDOR NAME	ACCOUNT #	ACCOUNT NAME	ITEM/REASON	INVOICE #	VP DATE	DATE TBP	PO NO	AMOUNT
O'REILLY AUTOMOTIVE STO	2017 213-613-321	MAINTENANCE SUPP	UNIT 315 - FUEL FIL	0763-122179	04/06/2017	04/10/2017	303861	37.77
O'REILLY AUTOMOTIVE STO	2017 213-613-321	MAINTENANCE SUPP	UNIT 316 - FUEL FIL	0763-122179	04/06/2017	04/10/2017	303861	19.42
O'REILLY AUTOMOTIVE STO	2017 213-613-321	MAINTENANCE SUPP	OIL-DRI ABSORBENT	0763-122628	04/07/2017	04/10/2017	302544	19.47
O'REILLY AUTOMOTIVE STO	2017 213-613-321	MAINTENANCE SUPP	UNIT 315 - OIL FILT	0763-122206	04/07/2017	04/10/2017	302544	22.40
O'REILLY AUTOMOTIVE STO	2017 213-613-321	MAINTENANCE SUPP	UNIT 316 - OIL FILT	0763-122206	04/07/2017	04/10/2017	302544	22.40
RATTLER ROCK INC	2017 213-613-376	ROAD MATERIAL	SW4250, SW4220	118093	04/07/2017	04/10/2017	302584	551.67
RATTLER ROCK INC	2017 213-613-376	ROAD MATERIAL	SW4220	118107	04/07/2017	04/10/2017	302584	281.33
RATTLER ROCK INC	2017 213-613-376	ROAD MATERIAL	SW4220	118136	04/07/2017	04/10/2017	302584	285.07
RATTLER ROCK INC	2017 213-613-376	ROAD MATERIAL	RSP	118267	04/07/2017	04/10/2017	302584	841.76
RATTLER ROCK INC	2017 213-613-376	ROAD MATERIAL	NW3180	118315	04/07/2017	04/10/2017	302584	430.60
RATTLER ROCK INC	2017 213-613-376	ROAD MATERIAL	NW3230, NW3220	118335	04/07/2017	04/10/2017	302584	286.12
RATTLER ROCK INC	2017 213-613-376	ROAD MATERIAL	NW3220, NW3240	118373	04/07/2017	04/10/2017	302584	289.74
RATTLER ROCK INC	2017 213-613-376	ROAD MATERIAL	NW3240, NW3230	118388	04/07/2017	04/10/2017	302584	429.23
RATTLER ROCK INC	2017 213-613-376	ROAD MATERIAL	NW3240, NW3230	118411	04/07/2017	04/10/2017	302584	430.05
RATTLER ROCK INC	2017 213-613-376	ROAD MATERIAL	NW3245, NW4040	118430	04/07/2017	04/10/2017	302584	429.66
RATTLER ROCK INC	2017 213-613-376	ROAD MATERIAL	NW4240	118446	04/07/2017	04/10/2017	302584	140.97
RATTLER ROCK INC	2017 213-613-376	ROAD MATERIAL	SW4220	118466	04/07/2017	04/10/2017	302584	267.58
RATTLER ROCK INC	2017 213-613-376	ROAD MATERIAL	SW4220	118479	04/07/2017	04/10/2017	302584	132.28
TIMCO BLASTING & COATIN	2017 213-613-453	HAULING	SE1081	16897	04/07/2017	04/10/2017	302685	665.01
WINDSTREAM	2017 213-613-435	TELEPHONE	125020441 03/25/17	0441 - MAR 2	04/07/2017	04/10/2017		111.21
WINDSTREAM	2017 213-613-435	TELEPHONE	125220875 03/22/17	0875 - MAR 2	04/07/2017	04/10/2017		128.36
WINTERS OIL COMPANY	2017 213-613-370	GAS & OIL	1500 GAL DIESEL	549974	04/06/2017	04/10/2017	303866	2,873.70
WINTERS OIL COMPANY	2017 213-613-370	GAS & OIL	DIESEL FUEL ADDITIV	549974	04/06/2017	04/10/2017	303866	120.00
								59,999.53

ALL RECORDS FROM 04/10/2017 TO 04/10/2017 DATE-TO-BE-PAID

VENDOR NAME	ACCOUNT #	ACCOUNT NAME	ITEM/REASON	INVOICE #	VP DATE	DATE TBP	PO NO	AMOUNT
ATWOODS DISTRIBUTING LP	2017 214-614-321	MAINTENANCE SUPP	UNIT 459 - POWER ST	3003/37	04/06/2017	04/10/2017	302549	2.49
BIG H TIRE SERVICE	2017 214-614-445	REPAIRS & MAINT	UNIT 47 - FLAT	164329	04/06/2017	04/10/2017	302551	25.00
CITY OF BLOOMING GROVE	2017 214-614-430	UTILITIES	EAST SECOND STREET	0002 - MAR 2	04/06/2017	04/10/2017		141.66
CORSICANA NAPA AUTO PAR	2017 214-614-321	MAINTENANCE SUPP	UNIT 455 - WIPER BL	064921	04/06/2017	04/10/2017	302552	20.08
GILFILLAN HARDWARE	2017 214-614-321	MAINTENANCE SUPP	15PC BIT SET	78901/1	04/06/2017	04/10/2017	302553	29.99
HUFFMAN COMMUNICATIONS	2017 214-614-450	MAINT CONTRACT	MAINTENANCE AGREEME	46749	04/07/2017	04/10/2017		41.13
LEGACY BULK TRUCKING CO	2017 214-614-453	HAULING	NW2290, BGSP	1265	04/07/2017	04/10/2017	303405	3,217.61
LEGACY BULK TRUCKING CO	2017 214-614-453	HAULING	BGSP	1262	04/07/2017	04/10/2017	302678	1,478.45
LEGACY BULK TRUCKING CO	2017 214-614-453	HAULING	BGSP	1263	04/07/2017	04/10/2017	302678	3,226.24
LEGACY BULK TRUCKING CO	2017 214-614-453	HAULING	BGSP	1264	04/07/2017	04/10/2017	302678	3,722.67
LEGACY BULK TRUCKING CO	2017 214-614-453	HAULING	NW2290, BGSP	1273	04/07/2017	04/10/2017	302678	3,151.00
O'REILLY AUTOMOTIVE STO	2017 214-614-321	MAINTENANCE SUPP	UNIT 455 - ALTERNAT	0763-124292	04/07/2017	04/10/2017	303886	100.79
PRECISION AUTO GLASS	2017 214-614-445	REPAIRS & MAINT	REPLACED WINDSHIELD	30511	04/06/2017	04/10/2017	303876	241.16
PROSPERITY BANK #107123	2017 214-614-573	CAPITAL LEASE PR	LOAN #1071239	APR 2017	04/07/2017	04/10/2017		3,873.42
PROSPERITY BANK #107123	2017 214-614-574	CAPITAL LEASE IN	LOAN #1071239	APR 2017	04/07/2017	04/10/2017		187.55
PROSPERITY BANK #107386	2017 214-614-573	CAPITAL LEASE PR	LOAN #1073861	MAR 2017	04/07/2017	04/10/2017		3,421.03
PROSPERITY BANK #107386	2017 214-614-574	CAPITAL LEASE IN	LOAN #1073861	MAR 2017	04/07/2017	04/10/2017		1,016.85
PROSPERITY BANK #107386	2017 214-614-573	CAPITAL LEASE PR	LOAN #1073861	APR 2017	04/07/2017	04/10/2017		3,696.16
PROSPERITY BANK #107386	2017 214-614-574	CAPITAL LEASE IN	LOAN #1073861	APR 2017	04/07/2017	04/10/2017		741.72
RATTLER ROCK INC	2017 214-614-376	ROAD MATERIAL	BGSP	118192	04/07/2017	04/10/2017	302679	432.42
TEXAS BIT	2017 214-614-376	ROAD MATERIAL	NW4190, NW4196	200567180	04/07/2017	04/10/2017	302682	1,928.25
WILLIAMS GIN & GRAIN CO	2017 214-614-321	MAINTENANCE SUPP	FITTING	359790	04/07/2017	04/10/2017	302561	5.00
WINDSTREAM	2017 214-614-435	TELEPHONE	125287122 03/19/17	7122 - MAR 2	04/07/2017	04/10/2017		56.22
WINTERS OIL COMPANY	2017 214-614-370	GAS & OIL	1800 GAL DIESEL	549810	04/06/2017	04/10/2017	303807	3,412.80

34,169.69

ALL RECORDS FROM 04/10/2017 TO 04/10/2017 DATE-TO-BE-PAID

VENDOR NAME	ACCOUNT #	ACCOUNT NAME	ITEM/REASON	INVOICE #	VP DATE	DATE TBP	PO NO	AMOUNT
AT&T SERVICES INC.	2017 232-455-435	TELEPHONE	287236363034 02/20/	3034 - MAR 2	04/04/2017	04/10/2017		244.30
XEROX CORP - TXMAS	2017 232-455-440	COPIER RENTAL	705029833 - MAR	088255520	03/08/2017	04/10/2017		110.12
XEROX CORP - TXMAS	2017 232-455-310	OFFICE SUPPLIES	705029833 - MAR	088255520	03/08/2017	04/10/2017		.84
XEROX CORP - TXMAS	2017 232-455-310	OFFICE SUPPLIES	705029833 - MAR	088255519	03/08/2017	04/10/2017		1.15
XEROX CORP - TXMAS	2017 232-455-310	OFFICE SUPPLIES	REFERENCE TO INV 08	088255518	03/08/2017	04/10/2017		4.28

352.13

ALL RECORDS FROM 04/10/2017 TO 04/10/2017 DATE-TO-BE-PAID

VENDOR NAME	ACCOUNT #	ACCOUNT NAME	ITEM/REASON	INVOICE #	VP DATE	DATE TBP	PO NO	AMOUNT
APRIL CARRASCO	2017 319-520-428	TRAVEL	NIBIN ACQUISITION T REIMB - 03/3	04/05/2017	04/10/2017			1,282.74
ATMOS ENERGY	2017 319-516-418	FACILITIES	3027278267 02/21/17 8267 - MAR 2	04/05/2017	04/10/2017			90.78
B & H PHOTO-VIDEO	2017 319-526-310	SUPPLIES	BOSE SOUNDSPORT WIR 124038285	04/06/2017	04/10/2017	303797		596.00
CITY OF ARLINGTON	2017 319-523-120	OVERTIME	BALI, MICHAEL 24.5 JAN 2017	04/04/2017	04/10/2017			1,416.30
CITY OF ARLINGTON	2017 319-523-120	OVERTIME	BALI, MICHAEL 31.5 DEC 2016	04/04/2017	04/10/2017			1,743.49
DALLAS COUNTY SHERIFF'S	2017 319-523-120	OVERTIME	RODRIGUEZ, VICTOR 3 JAN 2017	04/04/2017	04/10/2017			1,600.80
DALLAS COUNTY SHERIFF'S	2017 319-523-120	OVERTIME	RODRIGUEZ, VICTOR 6 DEC 2016	04/04/2017	04/10/2017			207.66
DALLAS COUNTY SHERIFF'S	2017 319-523-120	OVERTIME	SWANSON, JOSEPH 39 JAN 2017	04/04/2017	04/10/2017			1,903.72
DALLAS COUNTY SHERIFF'S	2017 319-526-120	OVERTIME	CASTILLO, PETE 8 OT DEC 2016	04/06/2017	04/10/2017			415.36
DAN CAUBLE	2017 319-520-411	SERVICES	03/01/17 - 03/31/17 2017-03	04/06/2017	04/10/2017			2,375.08
DELL MARKETING L P	2017 319-516-310	SUPPLIES	PORTABLE 1TB 3.0 US 10150826325	04/06/2017	04/10/2017	303643		515.98
FEDEX - TXMAS	2017 319-516-411	SERVICES	2934-0047-4 5-747-61525	04/04/2017	04/10/2017			169.89
FEDEX - TXMAS	2017 319-516-411	SERVICES	2934-0047-4 5-754-37395	04/05/2017	04/10/2017			39.31
GREG GARCIA	2017 319-520-428	TRAVEL	WEBPMP V2 SOFTWARE REIMB - 03/2	04/05/2017	04/10/2017			1,311.58
JOSE BARRON	2017 319-533-428	TRAVEL	MB-17-0043 CONTROL REIMB - 03/3	04/05/2017	04/10/2017			198.66
LGC PLUMBING INC	2017 319-516-418	FACILITIES	MATERIALS - NEW WAX 36057	04/06/2017	04/10/2017	303801		31.01
LGC PLUMBING INC	2017 319-516-418	FACILITIES	LABOR - 1.5 HRS RET 36057	04/06/2017	04/10/2017	303801		135.00
OFFICE BOY, LTD	2017 319-516-411	SERVICES	DISPOSED OFFICE FUR 44565	04/05/2017	04/10/2017	303103		1,800.00
OFFICE DEPOT INC-TXMAS	2017 319-526-310	SUPPLIES	EXAM GLOVES 912549111001	04/06/2017	04/10/2017	303775		209.90
OFFICE DEPOT INC-TXMAS	2017 319-526-310	SUPPLIES	KEYED PADLOCK 912549029001	04/06/2017	04/10/2017	303775		4.29
OFFICE DEPOT INC-TXMAS	2017 319-526-310	SUPPLIES	COPY PAPER 912371290001	04/06/2017	04/10/2017	303739		39.50
OFFICE DEPOT INC-TXMAS	2017 319-526-310	SUPPLIES	HP 508A TONERS - YE 912371290001	04/06/2017	04/10/2017	303739		375.14
OFFICE DEPOT INC-TXMAS	2017 319-526-310	SUPPLIES	HP 508A TONER - MAG 912371290001	04/06/2017	04/10/2017	303739		187.57
OFFICE DEPOT INC-TXMAS	2017 319-526-310	SUPPLIES	HP 508A TONERS - CY 912371290001	04/06/2017	04/10/2017	303739		375.14
OFFICE DEPOT INC-TXMAS	2017 319-526-310	SUPPLIES	HP 508A TONERS - BL 912371290001	04/06/2017	04/10/2017	303739		298.06
OFFICE DEPOT INC-TXMAS	2017 319-517-310	SUPPLIES	COPY PAPER 912351271001	04/06/2017	04/10/2017	303740		158.00
OFFICE DEPOT INC-TXMAS	2017 319-517-310	SUPPLIES	HP 05X TONER - BLAC 912351271001	04/06/2017	04/10/2017	303740		135.44
OFFICE DEPOT INC-TXMAS	2017 319-517-310	SUPPLIES	BATTERIES, CANNED A 912351271001	04/06/2017	04/10/2017	303740		147.20
OMNI PROFESSIONAL SERVI	2017 319-516-412	SERVICES	03/16/17 - 03/31/17 2017-6	04/05/2017	04/10/2017			3,976.17
REPUBLIC SERVICES #794	2017 319-516-418	FACILITIES	8404 ESTERS BLVD - 0794-0117533	04/04/2017	04/10/2017			254.96
RUTH ASTON	2017 319-517-412	SERVICES	03/16/17 - 03/31/17 2017-6	04/05/2017	04/10/2017			2,854.06
SHEILA COBB	2017 319-520-411	SERVICES	FACEBOOK FOR LAW EN 53151	04/06/2017	04/10/2017	303825		40.00
SUDDENLINK	2017 319-521-411	SERVICES	1000018626710322302 2302 - APR 2	04/05/2017	04/10/2017			347.71
SUMPTER SERVICES LLC	2017 319-515-412	SERVICES	03/16/17 - 03/31/17 2017-6	04/05/2017	04/10/2017			8,190.86
THOMAS PAUL HARRIS	2017 319-535-412	SERVICES	03/16/17 - 03/31/17 2017-6	04/05/2017	04/10/2017			3,167.81
TINA NASHEED	2017 319-520-411	SERVICES	FACEBOOK FOR LAW EN 53080	04/06/2017	04/10/2017	303826		40.00
VERIZON WIRELESS INC	2017 319-521-411	SERVICES	613180096-00001 02/ 9782486648	04/06/2017	04/10/2017			655.64

 37,290.81

TOTAL PAYABLES

414,765.75

CONTRACT AGREEMENT

THIS AGREEMENT, made the 28th day of February, 2017, by and between the Navarro SWCD, Corsicana, Texas (hereinafter called Owner) and Janek & Whitten Construction, Inc, Hillsboro, TX (hereinafter called Contractor).

WITNESSETH:

THAT WHEREAS: in accordance with law, Owner had contract documents prepared and an Invitation for Bids published, for and in connection with the repairs of flood prevention structure Richland Creek Site 31, Navarro County, Texas; and

WHEREAS, Contractor, in response to the Invitation for Bids, has submitted to Owner, in the manner and at the time specified, a sealed bid in accordance with Instructions to Bidders; and

WHEREAS, Owner, in the manner prescribed by law, has publicly opened, examined, and canvassed the bids submitted, and has determined Contractor to be the lowest responsible bidder for the work and duly awarded to Contractor a contract therefor, for the sum or sums named in Contractor's bid.

NOW, THEREFORE, in consideration of the compensation to be paid to Contractor and of the mutual agreements herein contained, the parties have agreed and hereby agree, Owner for itself and its successors and assigns, and its, his/her, or their executors and administrators, as follows:

ARTICLE I. Contractor shall perform all work, including the assumption of all obligations, duties and responsibilities necessary to the successful completion of the contract and the furnishing of all materials and equipment required to be incorporated in and form a permanent part of the work; tools, equipment, supplies, transportation, facilities, labor, superintendence and services required to perform the work; and bonds, insurance and submittals; all as indicated or specified in the contract documents to be performed or furnished by Contractor for the work included in and covered by Owner's official award of this contract to Contractor, such award being based on the acceptance by Owner of Contractor's bid.

ARTICLE II. Owner shall pay to Contractor for performance of the work embraced in this contract, and Contractor shall accept as full compensation therefor, the sum (subject to adjustment as provided in the contract documents) of Seven hundred-eighty-nine thousand eight hundred-fifty dollars and twenty-five cents (\$789,850.25) for all work covered by and included in the contract award and designated in the foregoing Article I; payment thereof to be made in current funds in the manner provided in the contract documents.

ARTICLE III. The Contractor shall complete all work within one hundred-twelve (112) calendar days from the date Contractor receives written Notice to Proceed.

ARTICLE IV. The contract documents that comprise the Contract between Owner and Contractor, attached hereto and made a part hereof, consist of the following:

This Contract Agreement:

- (1) Contractor's Bid: Exhibits A - F.
- (2) Addenda Numbers 1-2
- (3) Post-bid information and supplementary information submitted by Contractor prior to execution of this Contract Agreement.
- (4) Notice of Award.
- (5) PART II - General Conditions.

- (6) PART III – Supplemental Conditions.
- (7) PART IV – Construction Specifications.
- (8) PART V – Drawings No. TX-EN-0650.
- (9) PART VI – Prevailing Wage Rates Determination.
- (10) PART VII – Storm Water Pollution Prevention Plan
- (11) Notice to Proceed.
- (12) Any modifications (change orders) duly delivered or supplemental agreements duly entered into after execution of this Contract Agreement.
- (13) Notices of Final Completion and Acceptance.

IN WITNESS WHEREOF, the parties hereto have executed this Contract Agreement the day and year first above written.

OWNER
NAVARRO SWCD

CONTRACTOR

By **BOBBY WILSON**
Contracting Officer for
Navarro SWCD

By **DERRECK WHITTEN**
President, Janek and Whitten Construction
(CORPORATE SEAL)

Attest Bobby D. Wilson

Attest [Signature]

Address for giving notices:
Navarro SWCD
4323 West Highway 22,
Corsicana, Texas 75110

Address for giving notices
142 FM 3267
Hillsboro, TX 76645

This action authorized at an official meeting
of the Navarro SWCD on
March 17, 2017, Corsicana, Texas

License No. _____

Agent for service of process:

Bobby D. Wilson

(If CONTRACTOR is a corporation, attach

Navarro SWCD evidence of authority to sign.)

PART II - GENERAL CONDITIONS

ARTICLE 1 – DEFINITIONS

Terms used or referred to herein and elsewhere in the contract documents are defined as follows:

(a) Contracting Local Organization (CLO): The organization or agency awarding the contract. (CLO) is the Navarro SWCD, Corsicana, Texas, also referred to as Authority, Government, and Owner.

(b) Contracting Officer (CO): The person who is designated and authorized to enter into and administer this contract on behalf of the Contracting Local Organization or his/her duly appointed successor or alternate. No other person has authority to act for the Contracting Officer as stated in these General Conditions or elsewhere in the contract documents unless such person has been delegated authority by the Contracting Officer in writing, also referred to as Owner's Representative.

(c) Engineer: The person or his/her representative who is responsible for determining that the Contractor's work conforms to the technical requirements as set forth in the drawings and specifications, also called Project Engineer, Contracting Officer's Representative (COR).

(d) Inspector: The person who performs daily inspection services for the CLO at the construction site and maintains accurate daily records of the work accomplished and the factors affecting its progress and quality, also called NRCS Construction Inspector.

(e) USDA-NRCS. United States Department of Agriculture, Natural Resources Conservation Service – the Federal agency providing engineering and inspection services for this contract.

(f) Quality Assurance (QA). NRCS Construction Inspector (onsite).

(g) Quality Control (QC). Contractor's Construction Inspector (onsite).

ARTICLE 2 – SPECIFICATIONS AND DRAWINGS

The Contractor shall keep on the worksite a copy of the drawings and specifications and shall at all times give the Contracting Officer access thereto. Anything mentioned in the specifications and not shown on the drawings, or shown on the drawings and not mentioned in the specifications, shall be of like effect as if shown or mentioned in both. In case of difference between drawings and specifications, the specifications shall govern. In case of discrepancy either in the figures, in the drawings, or in the specifications, the matter shall be promptly submitted to the Contracting Officer, who shall promptly make a determination in writing. Any adjustment by the Contractor without such a determination shall be at his/her own risk and expense. The Contracting Officer shall furnish from time to time such detail drawings and other information as considered necessary, unless otherwise provided.

ARTICLE 3 – CHANGES

(a) The Contracting Officer may, at any time, without notice to the sureties, by written order designated or indicated to be a change order, make any change in the work within the general scope of the contract, including but not limited to changes:

- (1) In the specifications (including drawings and designs);
- (2) In the method or manner of performance of the work;

(3) In the Contracting Local Organization-furnished facilities, equipment, materials, services, or site; or

(4) Directing acceleration in the performance of the work.

(b) Any other written order or an oral order (which terms as used in this paragraph (b) shall include direction, instruction, interpretation, or determination) from the Contracting Officer, which causes any such change, shall be treated as a change order under this article, provided that the Contractor gives the Contracting Officer written notice stating the date, circumstances, and source of the order and that the Contractor regards the order as a change order.

(c) Except as herein provided, no order, statement, or conduct of the Contracting Officer shall be treated as a change under this article or entitle the Contractor to an equitable adjustment hereunder.

(d) If any change under this article causes an increase or decrease in the Contractor's cost of, or the time required for, the performance of any part of the work under this contract, whether or not changed by any order, an equitable adjustment shall be made and the contract modified in writing accordingly: *Provided, however,* That except for claims based on defective specifications, no claim for any change under (b) above shall be allowed for any costs incurred more than 20 days before the Contractor gives written notice as therein required: *And provided further,* That in the case of defective specifications for which the Contracting Local Organization is responsible, the equitable adjustment shall include any increased cost reasonably incurred by the Contractor in attempting to comply with such defective specifications.

(e) If the Contractor intends to assert a claim for an equitable adjustment under this article, Contractor must, within 30 days after receipt of a written change order under (a) above or the furnishing of a written notice under (b) above, submit to the Contracting Officer a written statement setting forth the general nature and monetary extent of such claim, unless this period is extended by the Contracting Officer. The statement of claim hereunder may be included in the notice under (b) above.

(f) No claim by the Contractor for an equitable adjustment hereunder shall be allowed if asserted after final payment under this contract.

ARTICLE 4 – DIFFERING SITE CONDITIONS

(a) The Contractor shall promptly, and before such conditions are disturbed, notify the Contracting Officer in writing of (1) subsurface or latent physical conditions at the site differing materially from those indicated in this contract, or (2) unknown physical conditions at the site, of an unusual nature, differing materially from those ordinarily encountered and generally recognized as inhering in work of the character provided for in this contract. The Contracting Officer shall promptly investigate the conditions, and if he/she finds that such conditions do materially so differ and cause an increase or decrease in the Contractor's cost of, or the time required for, performance of any part of the work under this contract, whether or not changed as a result of such conditions, an equitable adjustment shall be made and the contract modified in writing accordingly.

(b) No claim of the Contractor under this article shall be allowed unless the Contractor has given the notice required in (a) above; provided, however, the time prescribed therefor may be extended by the Contracting Officer.

(c) No claim by the Contractor for an equitable adjustment hereunder shall be allowed if asserted after final payment under this contract.

ARTICLE 5 – TERMINATION FOR DEFAULT, DAMAGES FOR DELAY, TIME EXTENSIONS

(a) If the Contractor refuses or fails to prosecute the work, or any separable part thereof, with such diligence as will insure its completion within the time specified in this contract, or any extension thereof, or fails to complete said work within such time, the Contracting Local Organization may, by written notice to the Contractor, terminate Contractor’s right to proceed with the work or such part of the work as to which there has been delay. In such event the Contracting Local Organization may take over the work and prosecute the same to completion, by contract or otherwise, and may take possession of and utilize in completing the work such materials, appliances, and plant as may be on the site of the work and necessary therefor. Whether or not the Contractor’s right to proceed with the work is terminated, Contractor and his/her sureties shall be liable for any damage to the Contracting Local Organization resulting from his/her refusal or failure to complete the work within the specified time.

(b) If the Contracting Local Organization so terminates the Contractor’s right to proceed, the resulting damage will consist of such actual damages until such reasonable time as may be required for final completion of the work together with any increased costs occasioned the Contracting Local Organization in completing the work.

(c) If the Contracting Local Organization does not so terminate the Contractor’s right to proceed, the resulting damage will consist of such actual damages until the work is completed or accepted.

(d) The Contractor’s right to proceed shall not be so terminated nor the Contractor charged with resulting damage if:

(1) The delay in the completion of the work arises from unforeseeable causes beyond the control and without the fault or negligence of the Contractor, including but not restricted to, acts of God, acts of the public enemy, acts of the Contracting Local Organization in its contractual capacity, acts of another contractor in the performance of a contract with the Contracting Local Organization, fires, floods, epidemics, quarantine restrictions, strikes, freight embargoes, unusually severe weather, or delays of subcontractors or suppliers arising from unforeseeable causes beyond the control and without the fault or negligence of both the Contractor and such subcontractors or suppliers; and

(2) The Contractor, within 10 days from the beginning of any such delay (unless the Contracting Officer grants a further period of time before the date of final payment under the contract), notifies the Contracting Officer in writing of the causes of delay.

The Contracting Officer shall ascertain the facts and the extent of the delay and extend the time for completing the work when, in his/her judgment, such an extension is justified.

(e) The rights and remedies of the Contracting Local Organization provided in this article are in addition to any other rights and remedies provided by law or under this contract.

(f) As used in paragraph (d)(1) of this article, the term “subcontractors and suppliers” means subcontractors and suppliers at any tier.

ARTICLE 6 – CLAIMS

Any claim by the Contractor arising by virtue of this contract which is not disposed of by agreement shall be submitted in writing, together with any written and oral evidence in support thereof, to the Contracting Officer for decision. Before making a decision, the Contracting Officer shall notify the Contractor that any additional written and/or oral evidence in support of the claim may be presented to the Contracting Officer within 30 days from receipt by the Contractor of such notification, or within such further period of time as may be granted by the Contracting Officer. The Contracting Officer shall make a decision in writing and mail or otherwise furnish a signed copy thereof to the Contractor. Pending the decision of the Contracting Officer the Contractor shall proceed diligently with the performance of this contract. *[See Also: PART III, Supplemental Conditions, Article 11 – Disputes/Alternative Dispute Resolution]*

ARTICLE 7 – PAYMENTS TO CONTRACTOR / INVOICING REQUIREMENTS

(a) The Contracting Local Organization will pay the contract price as hereinafter provided.

(b) The Contracting Local Organization will make will make regular progress payments as the work proceeds at intervals payment based on final quantities as approved by the Contracting Officer.

(c) “Properly Executed Invoice” Requirements

(1) The original and one copy of each invoice are to be delivered to the Contracting Officer at the designated payment office.

(2) One copy of each invoice and complete documentation of computations and supporting data as required by PART IV, Construction Specification 7 are to be submitted to the Engineer.

(3) The following must be attached to the original invoice submitted to the Contracting Officer and to the copy submitted to the Engineer:

(i) A complete remittance address along with vendor’s tax identification number.

(ii) Billing period.

(iii) Itemization of payment requests by Contract Item Number (CIN) as shown in PART I, Subpart C, Exhibit B—Bid Schedule, of the contract. Invoice will include the quantity performed that is being invoiced, the unit price (if applicable) and the CIN total price, and a sum total of amount of payment requested. Invoice will also include the cumulative quantities and amount by CIN.

(e) Designated Payment Office Contact Point. The contact point described below coordinates the issuance of payments under this contract:

Name: Bobby Wilson

Title: Contracting Officer

Address: Navarro SWCD, 4323 West Highway 22, Corsicana, Texas 75110

Telephone: (903) 874-5131 x3

(f) Final Payment Request

(1) The Contracting Local Organization shall pay the amount due the Contractor under this contract after--

(i) Completion and acceptance of all work;

(ii) Presentation of a properly executed invoice; and
 (iii) Presentation of release as indicated in (g)(3) below.

(2) The **FINAL** invoice billing shall include the following information:

(i) All documentation called for in the contract documents, and
 (ii) Consent of the surety, if required, to final payment.
 (iii) Complete and legally effective releases or waivers (satisfactory to Contracting Local Organization) of all liens arising out of or filed in connection with the work. In lieu thereof and as approved by Contracting Local Organization, Contractor may furnish receipts or releases in full; an affidavit of Contractor that the releases and receipts include all labor, services, material and equipment for which a lien could be filed, and that all payrolls, material and equipment bills, and other indebtedness connected with the work for which Contracting Local Organization or his/her property might in any way be responsible, have been paid or otherwise satisfied. If any subcontractor, manufacturer, fabricator, supplier, or distributor fails to furnish a release of receipt in full, Contractor may furnish a bond or other collateral satisfactory to Contracting Local Organization to indemnify Contracting Local Organization against any lien per TX Property Code, Chapter 53.

(3) The **FINAL** invoice shall also contain the following **RELEASE OF CLAIMS** statement:
 "I, Derreck Whitten, President, Janek & Whitten Construction, Inc., Hillsboro, Texas, do hereby release the Navarro SWCD, Corsicana, Texas, from any and all claims of any character whatsoever arising under and by virtue of contract number NSWCD-17-RCS31-02 dated February 28, 2017 as amended, except as herein stated [*LIST any Exceptions*].

 (Date of Release)

 (Signature of Contractor)

(4) Releases may also be required of the assignee if the Contractor's claim to amounts payable under this contract has been assigned under Article 25 of these General Conditions – Assignment, of this contract.

(h) This contract is subject to regulations incorporated in Texas Government Code, Subtitle F, Chapter 2251 – Payment for Goods and Services, regarding payment due dates, late payment interest, and claims and disputes. These regulations include, but are not limited to, payments made by Contracting Local Organization, Contractor, and subcontractors for any work, goods, services, etc. provided under this contract.

ARTICLE 8 – MATERIAL AND WORKMANSHIP

(a) Unless otherwise specifically provided in this contract, all equipment, material, and articles incorporated in the work covered by this contract are to be new and of the most suitable grade for the purpose intended. Unless otherwise specifically provided in this contract, reference to any equipment, material, article, or patented process, by trade name, make, or catalog number, shall be regarded as establishing a standard of quality and shall not be construed as limiting competition, and the Contractor may, at his/her option, use any equipment, material, article, or process which in the judgment of the Contracting Officer, is equal to that named. The Contractor shall furnish to the Contracting Officer for his/her approval the name of the manufacturer, the

model number, and other identifying data and information respecting the performance, capacity, nature, and rating of the machinery and mechanical and other equipment which the Contractor contemplates incorporating in the work. When required by this contract or when called for by the Contracting Officer, the Contractor shall furnish the Contracting Officer for approval full information concerning the material or articles which Contractor contemplates incorporating in the work. When so directed, samples shall be submitted for approval at the Contractor's expense, with all shipping charges prepaid. Machinery, equipment, material, and articles installed or used without required approval shall be at the risk of subsequent rejection.

(b) All work under this contract shall be performed in a skillful and workmanlike manner. The Contracting Officer may, in writing, require the Contractor to remove from the work any employee the Contracting Officer deems incompetent, careless, or otherwise objectionable.

ARTICLE 9 – INSPECTION, ACCEPTANCE AND LIQUIDATED DAMAGES.

(a) All work (which term includes but is not restricted to materials, workmanship, and manufacture and fabrication of components) shall be subject to inspection and test by the Contracting Local Organization at all reasonable times and at all places prior to acceptance. Any such inspection and test is for the sole benefit of the Contracting Local Organization and shall not relieve the Contractor of the responsibility of providing quality control measures to assure that the work strictly complies with the contract requirements. No inspection or test by the Contracting Local Organization shall be construed as constituting or implying acceptance. Inspection or test shall not relieve the Contractor of responsibility for damage to or loss of the material prior to acceptance, nor in any way affect the continuing rights of the Contracting Local Organization after acceptance of the completed work under the terms of paragraph (f) of this article, except as herein above provided.

(b) The Contractor shall, without charge, replace any material or correct any workmanship found by the Contracting Local Organization not to conform to the contract requirements, unless in the public interest the Contracting Local Organization consents to accept such material or workmanship with an appropriate adjustment in contract price. The Contractor shall promptly segregate and remove rejected material from the premises.

(c) If the Contractor does not promptly replace rejected material or correct rejected workmanship, the Contracting Local Organization (1) may, by contract or otherwise, replace such material or correct such workmanship and charge the cost thereof to the Contractor, or (2) may terminate the Contractor's right to proceed in accordance with the article of this contract entitled

“Termination for Default - Damages for Delay – Time Extensions.”

(d) The Contractor shall furnish promptly, without additional charge, all facilities, labor, and material reasonably needed for performing such safe and convenient inspection and test as may be required by the Point of Contact. All inspection and test by the Contracting Local Organization shall be performed in such manner as not unnecessarily to delay the work. Special, full size, and performance tests shall be performed as described in this contract. The Contracting Local Organization reserves the right to charge to the Contractor any additional cost of inspection or test when material or workmanship is not ready at the time specified by the Contractor for inspection or test or when reinspection or retest is necessitated by prior

rejection.

- (e) Should it be considered necessary or advisable by the Contracting Local Organization at any time before acceptance of the entire work to make an examination of work already completed, by removing or tearing out same, the Contractor shall, on request, promptly furnish all necessary facilities, labor, and material. If such work is found to be defective or nonconforming in any material respect, due to the fault of the Contractor or his/her subcontractors, Contractor shall defray all the expenses of such examination and of satisfactory reconstruction. If, however, such work is found to meet the requirements of the contract, an equitable adjustment shall be made in the contract price to compensate the Contractor for the additional services involved in such examination and reconstruction and, if completion of the work has been delayed thereby, Contractor shall, in addition, be granted a suitable extension of time.
- (f) Unless otherwise provided in this contract, acceptance by the Contracting Local Organization shall be made as promptly as practicable after completion and inspection of all work required by this contract, or that portion of the work that the Point of Contact determines can be accepted separately. Acceptance shall be final and conclusive except as regards latent defects, fraud, or such gross mistakes as may amount to fraud, or as regards the Contracting Local Organization's rights under any warranty or guarantee.
- (g) If the work is not completed within the time stipulated in the provided contract, the Contractor shall pay to the Locality actual liquidated damages incurred by the CLO and its Quality Assurance technical engineer and inspector for each calendar day of delay, until work is completed. The Contractor and his sureties shall be liable to the Navarro SWCD for the amount thereof.
- (h) Any amount due to the Navarro SWCD as a result of Liquidated Damages shall be deducted from the final payment due to the contractor.

ARTICLE 10 – SUPERINTENDENCE BY CONTRACTOR

The Contractor, at all times during performance and until the work is completed and accepted, shall give his/her personal superintendence to the work or have on the work a competent superintendent, satisfactory to the Contracting Officer and with authority to act for the Contractor.

ARTICLE 11 – PERMITS AND RESPONSIBILITIES

The Contractor shall, without additional expense to the Contracting Local Organization, be responsible for obtaining any necessary licenses and permits, and for complying with any applicable Federal, State, and municipal laws, codes, and regulations, in connection with the prosecution of the work. Contractor shall be similarly responsible for all damages to persons or property that occur as a result of his/her fault or negligence. He/she shall take proper safety and health precautions to protect the work, the workers, the public, and the property of others. He/she shall also be responsible for all materials delivered and work performed until completion and acceptance of the entire construction work, except for any completed unit of construction thereof which theretofore may have been accepted.

ARTICLE 12 – CONDITIONS AFFECTING THE WORK

The Contractor shall be responsible for having taken steps reasonably necessary to ascertain the nature and location of the work, and the general and local conditions which can affect the work or the cost thereof. Any failure by the Contractor to do so will not relieve Contractor from responsibility for successfully performing the work without additional expense to the Contracting Local Organization. The Contracting Local Organization assumes no responsibility for any understanding or representations concerning conditions made by any of its officers or agents prior to the execution of this contract, unless such understanding or representations by the Contracting Local Organization are expressly stated in the contract.

ARTICLE 13 – OTHER CONTRACTS

The Contracting Local Organization may undertake or award other contracts for additional work, and the Contractor shall fully cooperate with such other contractors and Contracting Local Organization employees and carefully fit his/her own work to such additional work as may be directed by the Contracting Officer. The Contractor shall not commit or permit any act which will interfere with the performance of work by any other contractor or by Contracting Local Organization employees.

ARTICLE 14 – PATENT INDEMNITY

Except as otherwise provided, the Contractor agrees to indemnify the Contracting Local Organization and its officers, agents and employees against liability, including costs and expenses, for infringement upon any Letters Patent of the United States (except Letters Patent issued upon an application which is now or may hereafter be, for reasons of national security, ordered by the Government to be kept secret or otherwise withheld from issue) arising out of the performance of this contract or out of the use or disposal by or for the account of the Contracting Local Organization of supplies furnished or work performed hereunder.

ARTICLE 15 – ADDITIONAL BOND SECURITY

If any surety upon any bond furnished in connection with this contract becomes unacceptable to the Contracting Local Organization, or if any such surety fails to furnish reports as to its financial condition from time to time as requested by the Contracting Local Organization, or if the contract price is increased to such an extent that the penal sum of any bond becomes inadequate in the opinion of the Contracting Officer, the Contractor shall promptly furnish such additional security as may be required from time to time to protect the interests of the Contracting Local Organization and of persons supplying labor or materials in the prosecution of the work contemplated by this contract.

ARTICLE 16 – REAL PROPERTY RIGHTS

(a) Adequate real property rights needed in order to perform the work under this contract have been acquired by or on behalf of the Contracting Local Organization. The right to enter, remove, or otherwise make use of adjacent property, roads, utility lines, fences, and other

improvements not included within the real property rights provided shall be the sole responsibility of the Contractor.

(b) Where ingress and egress is not defined on the drawings, the Contracting Officer shall designate the right-of-way to be used.

(c) The Contractor shall obtain owner's advance written approval if he/she plans to enter, remove, or otherwise make use of adjacent property, roads, utility lines, fences, and other improvements not included within the real property rights provided by the Contracting Local Organization. A copy of the written approval must be submitted to the Contracting Officer. The Contractor is responsible for any and all expenses associated with these items.

ARTICLE 17 – RECORDS OF TEST PITS AND BORINGS

The Contracting Local Organization does not represent that the available records show completely the existing conditions and does not guarantee any interpretation of these records. The Contractor assumes all responsibility for deductions and conclusions as to the nature of rock and other materials to be excavated, the difficulties of making and maintaining the required excavations and of doing other work affected by the geology of the site of the work, and for the final preparation of the foundations for the spillway, dikes, and other structures.

ARTICLE 18 – MATERIALS TO BE FURNISHED BY THE CONTRACTOR

(a) Unless otherwise specified in this contract, the Contractor shall furnish all materials required for the completion of the contract.

(b) Unless otherwise waived in writing by the Contracting Officer, the Contractor shall furnish the Contracting Local Organization with certifications dated and signed by the manufacturer and/or supplier to the effect that the items listed therein meet the requirements of this contract. Such certifications shall be furnished prior to the use of the material in any part of the construction and shall identify the project on which the material is to be used.

ARTICLE 19 – WATER

Unless otherwise specified in this contract, the Contractor shall provide and maintain at his/her own expense an adequate supply of water suitable for purposes of performing the work.

ARTICLE 20 – WORKWEEK—CONSTRUCTION SCHEDULE

(a) Unless furnished prior to contract award, the Contractor shall, prior to commencement of work, submit to the Contracting Officer for approval: (1) a construction schedule showing the order in which he/she proposes to carry on the work indicating the periods during which he/she will perform work on each item listed in the bid schedule; and (2) the hours and days in which he/she proposes to carry on the work.

(b) If, in the opinion of the Contracting Officer, the Contractor falls behind the approved construction schedule, the Contractor shall take such steps as may be necessary to improve his/her process and the Contracting Officer may require him/her to either increase the number of shifts, days or hours of work, or the amount of construction plant, or all of them, and to submit for approval such revised construction schedule as may be deemed necessary to show the manner in which the agreed rate of progress will be regained, all without additional cost to the

Contracting Local Organization. If the Contractor fails to submit a revised construction schedule within the time specified by the Contracting Officer, the Contracting Officer may withhold approval of progress payments and/or take such other actions as provided in this contract until such time as the Contractor submits the required construction schedule.

(c) Failure of the Contractor to comply with the requirements of the Contracting Officer under this article shall be grounds for determination by the Contracting Officer that the Contractor is not prosecuting the work with such diligence as will insure completion within the time specified. Upon such determination, the Contracting Officer may terminate the Contractor's right to proceed with the work, or any separable part thereof, in accordance with Article 5 of the General Conditions.

(d) The maximum workweek that will be approved is:

- Monday through Saturday, up to 11 hours per day, less Federal Shutdown days listed below:

Memorial Day: May 29, 2017

Independence Day: July 4, 2017

Labor Day: September 4, 2017

- Work is permitted during "daylight" hours only.

ARTICLE 21 – SUBCONTRACTORS

(a) Work shall not be subcontracted in whole or in part without the prior written approval of the Contracting Officer. The request shall be in writing with the name of the proposed subcontractor and a description of the work to be done.

(b) If at any time the Contracting Officer determines that any subcontractor is incompetent or undesirable, he/she shall notify the Contractor accordingly and the Contractor shall take immediate steps for cancellation of the subcontract.

(c) Subcontracting by subcontractors shall be subject to the above requirements.

(d) Nothing contained in this contract shall create any contractual relationship between any subcontractor and the Contracting Local Organization.

(e) Any subcontract awarded under this contract will not be awarded to any official of the Navarro SWCD (in the State of Texas), or to any firm in which any official or any member of such official's immediate family of these entities has direct or indirect interest in the pecuniary profits or contracts of such firms.

ARTICLE 22 – SURVEYS

See PART IV, Construction Specification 7 – Construction Surveys.

ARTICLE 23 – SUSPENSION OF WORK

(a) The Contracting Officer may order the Contractor in writing to suspend, delay, or interrupt all or any part of the work for such period of time as he/she may determine to be appropriate for the convenience of the Contracting Local Organization.

(b) If the performance of all or any part of the work is, for an unreasonable period of time, suspended, delayed, or interrupted by an act of the Contracting Officer in the administration of this contract, or by his/her failure to act within the time specified in this contract (or if no time is

specified, within a reasonable time), an adjustment shall be made for any increase in the cost of performance of this contract (excluding profit) necessarily caused by such unreasonable suspension, delay, or interruption and the contract modified in writing accordingly. However, no adjustment shall be made under this article for any suspension, delay, or interruption to the extent (1) that performance would have been so suspended, delayed, or interrupted by any other cause including the fault or negligence of the Contractor or (2) for which an equitable adjustment is provided for or excluded under any other provision of this contract.

(c) No claim under this article shall be allowed (1) for any costs incurred more than 20 days before the Contractor shall have notified the Contracting Officer in writing of the act or failure to act involved (but this requirement shall not apply as to a claim resulting from a suspension order), and (2) unless the claim, in an amount stated, is asserted in writing as soon as practicable after the termination of such suspension, delay, or interruption, but not later than the date of final payment under the contract.

ARTICLE 24 – CLEANUP WORK

(a) During performance of the work the Contractor shall keep the work site, areas adjacent to the work site and access roads in an orderly condition, free and clear from debris and discarded materials. Care shall be taken to prevent spillage when hauling is being done. Any spillage or debris resulting from the Contractor's operations shall be immediately removed.

(b) Upon completion of the work the Contractor shall remove from the work site, areas adjacent to the work site and access roads: all plant, buildings, debris, unused materials, concrete forms and other like material belonging to Contractor or used under his/her direction during the construction. Contractor shall grade all access roads, other than public, removing wheel tracks and smoothing up such roads.

ARTICLE 25 – ASSIGNMENT

The Contractor shall not assign in whole or in part this contract without the prior written consent of the Contracting Local Organization. The Contractor shall not assign any moneys due or to become due to him/her under this contract without the prior written consent of the Contracting Local Organization.

ARTICLE 26 – WEATHER

(a) The Contracting Officer may order suspension of the work in whole or in part, commencing with the day after receipt of the Notice to Proceed by the Contractor, due to weather or the effects of weather at the site, for such time as he/she considers it unfavorable for satisfactory prosecution of the work.

(b) When the Contracting Officer orders suspension under (a) of this article, the contract completion date shall be extended a full calendar day for each calendar day during suspension of the work if:

(1) All work is suspended except minor items as may be designated in this contract or as approved during the suspension period by the Contracting Officer at his/her sole discretion on a

case-by-case basis (work of an emergency, protective or maintenance nature may be performed at any time); and

(2) The hours lost in any one workday of the authorized workweek through suspension equal one-half or more of the hours of an authorized workday.

(c) If the Contracting Officer orders suspension of work as provided in (b) of this article and the hours lost in the workday immediately preceding a non-workday equal one-half or more of the hours in an authorized workday, the contract completion date shall be extended a full calendar day for each non-workday during suspension of the work.

(d) When the Contracting Officer orders any suspension of the work under this article, the Contractor shall not be entitled to any cost or damages resulting from such suspension.

(e) When the contract completion date is extended under this article, the contract shall be modified in writing accordingly.

ARTICLE 27 – NONCOMPLIANCE WITH CONTRACT REQUIREMENTS

(a) The Contracting Officer may order suspension of the work in whole or in part for such time as he/she deems necessary because of the failure of the Contractor to comply with any of the requirements of this contract, and the contract completion date shall not be extended on account of any such suspension of the work.

(b) When the Contracting Officer orders any suspension of the work under (a) of this article, the Contractor shall not be entitled to any costs or damages resulting from such suspension.

(c) The rights and remedies of the Contracting Local Organization provided in this article are in addition to any other rights and remedies provided by law or under this contract.

ARTICLE 28 – QUANTITY VARIATIONS

(a) Where the quantity of work shown for an item in the bid schedule, including any modification thereof, is estimated, no adjustment of the contract price nor of the performance time shall be made for overruns or underruns which are within 25 percent of the estimated quantity of any such item.

(b) For overruns of more than 25 percent, the Contracting Officer shall re-estimate the quantity for the item, establish an equitable contract price for the overrun of more than 25 percent, adjust contract performance time equitably, and modify the contract in writing accordingly; this article to thereafter be applicable to the total re-estimated item quantity.

(c) For underruns of more than 25 percent, the Contracting Officer shall determine the quantity for the item, establish an equitable contract price therefor, adjust contract performance time equitably, and modify the contract in writing accordingly.

ARTICLE 29 – FEDERAL, STATE, AND LOCAL TAXES

(a) Except as otherwise provided, contract unit prices shall include all applicable Federal, State, and local taxes.

(b) Texas State, County, and Municipal Sales and Use Tax. (1) The Contracting Local Organization is an exempt entity per §151.309(5) of the Limited Sales, Excise, and Use Tax Act (Texas Tax Code Chapter 151 – Limited Sales, Excise, and Use Tax) and will issue the Contractor an affidavit as proof of this exemption. This contract is a “lump-sum contract” as

defined by Texas Administrative Code, Title 34, Part 1, Chapter 3, Subchapter O – State Sales and Use Tax, Rule §3.291 (Contractors).

(2) When purchased by the Contractor for use in performance of this contract, certain tangible personal property and taxable services are exempt from State Sales and Use Tax under Texas Tax Code §151.311, and in most cases are also exempt from County and Municipal Sales and Use Tax. Contractor is subject to tax responsibilities in Texas Administrative Code Rule §3.291, section (c), and is responsible to issue a properly completed exemption certificate to a supplier in accordance with section (c)(5).

(3) Contractor is solely responsible to be adequately familiar with and comply with all requirements of Texas Tax Code, Texas Administrative Codes, and any other State/local regulations when claiming tax exemption for purchase of items for use in the performance of this contract.

(4) “Contractor” as used in this paragraph (b) includes subcontractors as defined in Texas Administrative Code Rule §3.291, section (a)(3).

ARTICLE 30 – SHOP DRAWINGS

(a) The term “shop drawings” includes drawings, diagrams, layouts, schematics, descriptive literature, illustrations, schedules, performance and test data, and similar materials furnished by the Contractor to explain in detail specific portions of the work required by the contract.

(b) If this contract requires shop drawings, the Contractor shall coordinate all such drawings, and review them for accuracy, completeness, and compliance with contract requirements and shall indicate his/her approval thereon as evidence of such coordination and review. Shop drawings submitted to the Contracting Officer without evidence of the Contractor’s approval may be returned for resubmission. The Contracting Officer will indicate his/her approval or disapproval of the shop drawings and if not approved as submitted shall indicate his/her reasons therefor. Any work done prior to such approval shall be at the Contractor’s risk. Approval by the Contracting Officer shall not relieve the Contractor from responsibility for any errors or omissions in such drawings, nor from responsibility for complying with the requirements of this contract, except with respect to variations described and approved in accordance with (c) below.

(c) If shop drawings show variations from the contract requirements, the Contractor shall describe such variations in writing, separate from the drawings, at the time of submission. If the Contracting Officer approves any such variation(s), he/she shall issue an appropriate contract modification, except that, if the variation is minor and does not involve a change in price or in time of performance, a modification need not be issued.

ARTICLE 31 – TERMINATION FOR CONVENIENCE OF THE CONTRACTING LOCAL ORGANIZATION

The Contracting Officer, by written notice, may terminate this contract in whole or in part, when it is in the interest of the Contracting Local Organization. If this contract is so terminated, the Contractor shall be compensated for all necessary and reasonable direct costs of performing the work actually accomplished. In addition, the Contractor shall be paid 10 percent for overhead expenses based on said direct costs, and 5 percent for profit based on the total of direct costs and overhead costs. From this will be deducted any payments or reimbursements previously paid

and salvage value of materials paid for by the Contracting Local Organization but not used. Provided however, no profit shall be paid if the Contractor would have incurred a loss had the entire contract been completed.

ARTICLE 32 – PROTECTION OF EXISTING VEGETATION, STRUCTURES, EQUIPMENT, UTILITIES, AND IMPROVEMENTS

(a) The Contractor shall preserve and protect all structures, equipment, and vegetation (such as trees, shrubs, and grass) on or adjacent to the work site, which are not to be removed and which do not unreasonably interfere with the work required under this contract. The Contractor shall only remove trees when specifically authorized to do so, and shall avoid damaging vegetation that will remain in place. If any limbs or branches of trees are broken during contract performance, or by the careless operation of equipment, or by workmen, the Contractor shall trim those limbs or branches with a clean cut and paint the cut with a tree-pruning compound as directed by the Contracting Officer.

(b) The Contractor shall protect from damage all existing improvements and utilities (1) at or near the work site, and (2) on adjacent property of a third party, the locations of which are made known to or should be known by the Contractor. The Contractor shall repair any damage to those facilities, including those that are the property of a third party, resulting from failure to comply with the requirements of this contract or failure to exercise reasonable care in performing the work. If the Contractor fails or refuses to repair the damage promptly, the Contracting Officer may have the necessary work performed and charge the cost to the Contractor.

ARTICLE 33 – OPERATIONS AND STORAGE AREAS

(a) The Contractor shall confine all operations (including storage of materials) on Contracting Local Organization premises to areas authorized or approved by the Contracting Officer. The Contractor shall hold and save the Contracting Local Organization, its officers and agents, free and harmless from liability of any nature occasioned by the Contractor's performance.

(b) Temporary buildings (e.g., storage sheds, shops, offices) and utilities may be erected by the Contractor only with the approval of the Contracting Officer and shall be built with labor and materials furnished by the Contractor without expense to the Contracting Local Organization. The temporary buildings and utilities shall remain the property of the Contractor and shall be removed by the Contractor at its expense upon completion of the work. With the written consent of the Contracting Officer, the buildings and utilities may be abandoned and need not be removed.

(c) The Contractor shall, under regulations prescribed by the Contracting Officer, use only established roadways, or use temporary roadways constructed by the Contractor when and as authorized by the Contracting Officer. When materials are transported in prosecuting the work, vehicles shall not be loaded beyond the loading capacity recommended by the manufacturer of the vehicle or prescribed by any Federal, State, or local law or regulation. When it is necessary to cross curbs or sidewalks, the Contractor shall protect them from damage. The Contractor shall repair or pay for the repair of any damaged curbs, sidewalks, or roads.

ARTICLE 34 – USE AND POSSESSION PRIOR TO COMPLETION

(a) The Contracting Local Organization shall have the right to take possession of or use any

completed or partially completed part of the work. Before taking possession of or using any work, the Contracting Officer shall furnish the Contractor a list of items of work remaining to be performed or corrected on those portions of the work that the Contracting Local Organization intends to take possession of or use. However, failure of the Contracting Officer to list any item of work shall not relieve the Contractor of responsibility for complying with the terms of the contract. The Contracting Local Organization's possession or use shall not be deemed an acceptance of any work under the contract.

(b) While the Contracting Local Organization has such possession or use, the Contractor shall be relieved of the responsibility for the loss of or damage to the work resulting from the Contracting Local Organization's possession or use, notwithstanding the terms of Article 11 (Permits and Responsibilities) of these General Conditions. If prior possession or use by the Contracting Local Organization delays the progress of the work or causes additional expense to the Contractor, an equitable adjustment shall be made in the contract price or the time of completion, and the contract shall be modified in writing accordingly.

ARTICLE 35 – LAYOUT OF WORK

See PART IV, Construction Specification 7 – Construction Surveys.

ARTICLE 36 – PRECONSTRUCTION CONFERENCE

If the Contracting Officer decides to conduct a preconstruction conference, the successful offeror will be notified and will be required to attend. The Contracting Officer's notification will include specific details regarding the date, time, and location of the conference, any need for attendance by subcontractors, and information regarding the items to be discussed.

ARTICLE 37 – CONTRACTOR RECORDS

(a) Access to Records. Contractor shall provide access by Contracting Local Organization, Texas State Soil and Water Conservation Board, or USDA-NRCS, or any of their duly authorized representatives, to any books, documents, papers, and records of the Contractor which are directly pertinent to the contract for the purpose of making audit, examination, excerpts, and transcriptions.

(b) Retention of Records. Contractor shall retain all records requiring access per paragraph (a) above for three (3) years after the Contracting Local Organization makes final payment under the contract and all other pending matters between the Contracting Local Organization and the Contractor under the contract are closed.

ARTICLE 38 – ARCHEOLOGICAL OR HISTORIC SITES

If a previously unidentified archeological or historic site(s) is encountered, the Contractor shall discontinue work in the general area of the site(s) and notify the Contracting Officer immediately.

ARTICLE 39 – CONTROL OF EROSION, SEDIMENTATION, AND POLLUTION

(a) Operations shall be scheduled and conducted to minimize erosion of soils and to prevent silting and muddying of streams, rivers, irrigation systems, and impoundments (lakes, reservoirs, etc.).

(b) Pollutants such as fuels, lubricants, bitumens, raw sewage, and other harmful materials shall not be discharged on the ground; into or nearby rivers, streams, or impoundments; or into natural or man-made channels. Wash water or waste from concrete or aggregate operations shall not be allowed to enter live streams prior to treatment by filtration, settling, or other means sufficient to reduce the sediment content to not more than that of the stream into which it is discharged.

(c) Mechanized equipment shall not be operated in flowing streams without written approval by the Contracting Officer.

ARTICLE 40 – [RESERVED]**ARTICLE 41 – ACCIDENT PREVENTION AND SAFETY**

(a) The Contractor shall provide and maintain work environments and procedures which will:

- (1) Safeguard the public and Contracting Local Organization personnel, property, materials, supplies, and equipment exposed to Contractor operations and activities;
- (2) Avoid interruptions of Contracting Local Organization operations and delays in project completion dates; and
- (3) Control costs in the performance of this contract.

(b) Whenever the Contracting Officer becomes aware of any noncompliance with these requirements or any condition which poses a serious or imminent danger to the health or safety of the public or Contracting Local Organization personnel, the Contracting Officer shall notify the Contractor orally, with written confirmation, and request immediate initiation of corrective action. This notice, when delivered to the Contractor or the Contractor's representative at the work site, shall be deemed sufficient notice of the noncompliance and that corrective action is required. After receiving the notice, the Contractor shall immediately take corrective action. If the Contractor fails or refuses to promptly take corrective action, the Contracting Officer may issue an order stopping all or part of the work until satisfactory corrective action has been taken. The Contractor shall not be entitled to any equitable adjustment of the contract price or extension of the performance schedule on any stop work order issued under this article.

(c) The Contractor shall insert this article, including this paragraph (c), with appropriate changes in the designation of the parties, in subcontracts.

(d) Before commencing the work, the Contractor shall--

- (1) Submit a written proposed plan for implementing this article. The plan shall include an analysis of the significant hazards to life, limb, and property inherent in contract work performance and a plan for controlling these hazards; and
- (2) Meet with representatives of the Contracting Officer to discuss and develop a mutual understanding relative to administration of the overall safety program.

(e) In the event there is a conflict between the requirements contained in the specifications, Contractor's safety program, and U.S. Department of Labor construction safety and health standards, the more stringent requirement will prevail.

(f) Contractor shall comply with OSHA (Occupational Safety and Health Administration) Parts 1910 and 1926 Construction Industry Standards and Interpretations, and with the supplement below:

Supplement to OSHA Parts 1910 and 1926 Construction Industry Standards and Interpretations

Requests for variances or waiver from this supplement are to be made to the Contracting Officer in writing supported by evidence that every reasonable effort has been made to comply with the contractual requirements. A written request for a waiver or a variance shall include--

- (1) Specific reference to the provision or standard in question;
- (2) An explanation as to why the waiver is considered justified; and
- (3) The Contractor's proposed alternative, including technical drawings, materials, or equipment specifications needed to enable Contracting Officer to render a decision.

No waiver or variance will be approved if it endangers any person. The Contractor shall not proceed under any requested revision of a provision until the Contracting Officer has given written approval. The Contractor is to hold and save harmless the United States Department of Agriculture, Natural Resources Conservation Service, and the Contracting Local Organization free from any claims or causes of action whatsoever resulting from the Contractor or Subcontractors proceeding under a waiver or approved variance.

Copies of OSHA Parts 1910 and 1926, Construction Industry Standards and Interpretations, may be obtained from:

Superintendent of Documents
U.S. Government Printing Office
Washington, DC 20402

A. GENERAL CONTRACTOR REQUIREMENTS

(1) **SAFETY PROGRAM.** Each Contractor is to demonstrate that he or she has facilities for conducting a safety program commensurate with the work under contract. The Contractor is to submit in writing a proposed comprehensive safety program to the Contracting Officer for approval before the start of operations. The program is to specifically state what provisions the Contractor proposes to take for the health and safety of all employees, including subcontractors and rental equipment operators. The program shall be site specific and provide details relevant to the work to be done, the hazards associated with the work, and the actions that will be necessary to minimize the identified hazards.

(2) **PRECONSTRUCTION SAFETY MEETING.** Representatives for the Contractor are to meet with the Contracting Officer or the CO's Representative before commencing work to

discuss the safety program and the implementation of all health and safety standards pertinent to the work under this contract.

(3) **JOINT SAFETY POLICY COMMITTEE.** The Contractor or designated on-site representative is to participate in monthly meetings of a joint Safety Policy Committee, composed of Contracting Officer, CLO Engineer and/or Inspector, and Contractor supervisory personnel. At these meetings the Contractor's project manager and the Contracting Officer will review the effectiveness of the Contractor's safety effort, resolve current health and safety problems, and coordinate safety activities for upcoming work.

(4) **SAFETY PERSONNEL.** Each Contractor is to designate a competent supervisory employee satisfactory to Contracting Officer to administer the safety program.

(5) **SAFETY MEETINGS.** A minimum of one "on-the-job" or "toolbox" safety meeting is to be conducted each week by all field supervisors or foremen and attended by mechanics and all personnel at the jobsite. The Contractor is to also conduct regularly scheduled supervisory safety meetings at least monthly for all levels of job supervision.

(6) **SAFETY INSPECTION.** The Contractor shall perform frequent and regular safety inspections of the jobsite, materials, and equipment, and shall correct deficiencies.

(7) **FIRST AID TRAINING.** Every Contractor foreman's work crew must include an employee who has a current first aid certificate from the Mine Safety and Health Administration, American Red Cross, or other state-approved organization.

(8) **REPORTS.** Each contractor is to maintain an accurate record of all job-related deaths, diseases, or disabling injuries. The records shall be maintained in a manner approved by the Contracting Officer. A copy of all reports is to be provided to the Contracting Officer. All fatal or serious injuries are to be reported immediately to the Contracting Officer, and every assistance is to be given in the investigation of the incident, including submission of a comprehensive narrative report to the Contracting Officer. Other occurrences with serious accident potential, such as equipment failures, slides, and cave-ins, must also be reported immediately. The Contractor is to assist and cooperate fully with the Contracting Officer in conducting accident investigations. The Contracting Officer is to be furnished all information and data pertinent to investigation of an accident.

(9) **CERTIFICATION OF INSURANCE.** Contractors are to provide the Contracting Officer with certificates of insurance before the start of operations indicating full compliance with State Worker's Compensation statutes, as well as other certificates of insurance required under the contract. *[See PART III – Supplemental Conditions, Articles 1, 2, and 3.]*

B. FIRST AID AND MEDICAL FACILITIES

(1) **FIRST AID KITS.** A 16-unit first aid kit approved by the American Red Cross is to be provided at accessible, well-identified, locations at the ratio of at least 1 kit for each 25 employees. The first aid kits are to be moistureproof and dusttight, and the contents of the kits are to be replenished as used or as they become ineffective or outdated.

(2) EMERGENCY FIRST AID. At least one employee certified to administer emergency first aid must be available on each shift and duly designated by the Contractor to care for injured employees. The names of the certified employees shall be posted at the jobsite.

(3) COMMUNICATION AND TRANSPORTATION. Prior to the start of work, the Contractor is to make necessary arrangements for prompt and dependable communications, transportation, and medical care for injured employees. At least one stretcher and two blankets shall be readily available for transporting injured employees.

(4) FIRST AID AND MEDICAL REPORTS. The Contractor is to maintain a record system for first aid and medical treatment on the jobsite. Such records are to be readily available to the Contracting Officer and are to include--

- (a) A daily treatment log listing chronologically all persons treated for occupational injuries and illnesses;
- (b) Cumulative record of injury for each individual;
- (c) Monthly statistical records of occupational injuries, classified by type and nature of injury; and
- (d) Required records for worker's compensation.

(5) SIGNS AND DIRECTIONAL MARKINGS. Adequate identification and directional markers are to be provided to readily denote the location of all first aid stations.

(6) EMERGENCY LISTING. A listing of telephone numbers and addresses of doctor, rescue squad, hospital, police, and fire departments is to be provided at all first aid locations.

C. PHYSICAL QUALIFICATIONS OF EMPLOYEES

(1) GENERAL REQUIREMENTS. Persons employed throughout the contract are to be physically qualified to perform their assigned duties. Employees must not knowingly be permitted or required to work while their ability or alertness is impaired by fatigue, illness, or any other reason that may jeopardize themselves or others.

(2) HOIST OPERATORS. Operators of cranes, cableways, and other hoisting equipment shall be examined annually by a physician and provided with a certification stating that they are physically qualified to safely operate hoisting equipment. The Contractor is to submit a copy of each certification to the Contracting Officer.

(3) HEAVY EQUIPMENT OPERATORS. It is recommended that operators of trucks and heavy equipment be given physical examinations to determine if they are physically qualified to perform their assigned work without endangering themselves or others.

(4) MOTOR VEHICLE OPERATORS. Operators of motor vehicles engaged primarily in the transportation of personnel are to be 18 years of age or older and have a valid state operator's permit or license for the equipment being operated.

(5) D. PERSONAL PROTECTIVE EQUIPMENT

(1) **HARD HAT AREAS.** The entire jobsite, with the exception of offices, shall be considered a hard hat area. All persons entering the area are, without exception, required to wear hard hats. The Contractor shall provide hard hats for visitors entering hard hat areas.

(2) **LABELS.** Hard hats shall bear a manufacturer's label indicating design compliance with the appropriate ANSI (American National Standards Institute) standard.

(3) **POSTING.**

(a) Signs at least 3 by 4 feet worded as follows with red letters (minimum 6 inches high) and white background shall be erected at access points to designated hard hat areas:

**CONSTRUCTION AREA - HARD HATS
REQUIRED BEYOND THIS POINT**

(b) These signs are to be furnished and installed by the Contractor at entries to shops, service yards, and job access points.

(4) **SAFETY GOGGLES (DRILLERS). DRILLERS AND HELPERS.** Drillers and helpers operating pneumatic rock drills must wear protective safety goggles.

E. MACHINERY AND MECHANIZED EQUIPMENT

(1) **SAFE CONDITION.** Before any machinery or mechanized equipment is initially used on the job, it must be inspected and tested by qualified personnel and determined to be in safe operating condition and appropriate for the intended use. Operators shall inspect their equipment prior to the beginning of each shift. Any deficiencies or defects shall be corrected prior to using the equipment. Safety equipment, such as seatbelts, installed on machinery is to be used by equipment operators.

(2) **TAGGING AND LOCKING.** The controls of power-driven equipment under repair are to be locked. An effective lockout and tagging procedure is to be established, prescribing specific responsibilities and safety procedures to be followed by the person or persons performing repair work. Mixer barrels are to be securely locked out before permitting employees to enter them for cleaning or repair.

(3) **HAUL ROADS FOR EQUIPMENT**

(a) **ROAD MAINTENANCE.** The Contractor shall maintain all roadways, including haul roads and access roads, in a safe condition so as to eliminate or control dust and ice hazards. Wherever dust is a hazard, adequate dust-laying equipment shall be available at the jobsite and utilized to control the dust.

(b) **SINGLE-LANE HAUL ROADS.** Single-lane haul roads with two-way traffic shall have adequate turnouts. Where turnouts are not practical, a traffic control system shall be provided to prevent accidents.

(c) **TWO-WAY HAUL ROADS.** On two-way haul roads, arrangements are to be such that vehicles travel on the right side wherever possible. Signs and traffic control devices are to be employed to indicate clearly any variations from a right-hand traffic pattern. The road shall

be wide enough to permit safe passage of opposing traffic, considering the type of hauling equipment used.

(d) DESIGN AND CONSTRUCTION OF HAUL ROADS. Haul road design criteria and drawings, if requested by the Contracting Officer, are to be submitted for approval prior to road construction. Sustained grades shall not exceed 12 percent and all curves shall have open-sight line with as great a radius as practical. All roads shall be posted with curve signs and maximum speed limits that will permit the equipment to be stopped within one-half the minimum sight distance.

(e) OPERATORS. Machinery and mechanized equipment shall be operated only by authorized qualified persons.

(f) RIDING ON EQUIPMENT. Riding on equipment by unauthorized personnel is prohibited. Seating and safety belts shall be provided for the operator and all passengers.

(g) GETTING ON OR OFF EQUIPMENT. Getting on or off equipment while the equipment is in motion is prohibited.

(h) HOURS OF OPERATION. Except in emergencies, an equipment operator shall not operate any mobile or hoisting equipment for more than 12 hours without an 8-hour rest interval away from the job.

(4) POWER CRANES AND HOISTS (TRUCK CRANES, CRAWLER CRANES, TOWER CRANES, GANTRY CRANES, HAMMERHEAD CRANES, DERRICKS, CABLEWAYS, AND HOISTS)

(a) PERFORMANCE TEST. Before initial on-site operation, at 12-month intervals, and after major repairs or modification, power cranes, derricks, cableways, and hoists must satisfactorily complete a performance test to demonstrate the equipment's ability to safely handle and maneuver the rated loads. The tests shall be conducted in the presence of a representative of the Contracting Officer (the Engineer and/or Inspector). Test data shall be recorded and a copy furnished to the Contracting Officer.

(b) PERFORMANCE TEST--POWER CRANES (CRAWLER MOUNTED, TRUCK MOUNTED, AND WHEEL MOUNTED). The performance test is to be carried out as per ANSI requirements. The test is to consist of raising, lowering and braking the load and rotating the test load through 360° at the specified boom angle or radius. Cranes equipped with jibs or boom tip extensions are to be tested using both the main boom and the jib, with an appropriate test load in each case.

(c) PERFORMANCE TEST--DERRICKS, GANTRY CRANES, TOWER CRANES, CABLEWAYS, AND HOISTS, INCLUDING OVERHEAD CRANES. This equipment is to be performance tested as per with ANSI requirements.

(d) BOOM ANGLE INDICATOR. Power cranes (including draglines) with booms capable of moving in the vertical plane shall be provided with a boom angle indicator in good working order.

(e) **CRANE TEST CERTIFICATION.** The performance test required by (4)(b) and (c) is fulfilled if the Contractor provides the Contracting Officer a copy of the certificate of inspection made within the past 12 months by a qualified person or by a government or private agency satisfactory to the Contracting Officer.

(f) **POSTING FOR HIGH VOLTAGE LINES.** A notice of the 10-foot (or greater) clearance required by OSHA 1926.550, Subpart N, shall be posted in the operator's cab of cranes, shovels, boom-type concrete pumps, backhoes, and related equipment.

(g) **BOOM STOPS.** Cranes or derricks with cable-supported booms, except draglines, shall have a device attached between the gantry of the A-frame and the boom chords to limit the elevation of the boom. The device shall control the vertical motions of the boom with increasing resistance from 83° or less, until completely stopping the boom at not over 87° above horizontal.

(h) **SAFETY HOOKS.** Hooks used in hoisting personnel or hoisting loads over construction personnel or in the immediate vicinity of construction personnel shall be forged steel equipped with safety keepers. When shackles are used under these conditions, they shall be of the locking type or have the pin secured to prohibit turning.

(5) ROLLOVER PROTECTIVE STRUCTURES (ROPS)

(a) **ROLLOVER PROTECTIVE STRUCTURES.** OSHA 1926, Subpart W, Overhead Protection, Sections 1001 and 1002 are applicable regardless of the year in which the equipment was manufactured and regardless of the struck capacity of the equipment.

(b) **EQUIPMENT REQUIRING ROPS.** The requirement for ROPS meeting (5)(a) above applies to crawler and rubber-tired tractors such as dozers, push-and-pull tractors, winch tractors, tractors with backhoes, and mowers; off-highway, self-propelled, pneumatic-tired earthmovers, including scrapers, motor graders and loaders; and rollers, compactors, water tankers (excluding trucks with cabs). These requirements shall also apply to agricultural and industrial tractors and similar equipment.

(c) **EQUIPMENT REQUIRING SEATBELTS.** The requirements for seatbelts as specified in OSHA Subpart O, Motor Vehicles, Mechanized Equipment, and Marine Operations, Section 1926.602 shall also apply to self-propelled compactors and rollers, and rubber-tired skid-steer equipment.

F. LADDERS AND SCAFFOLDING

(1) **LADDERS.** OSHA 1926, Subpart L - Section 450. Ladders shall be used as work platforms only when use of small hand tools or handling of light material is involved. No work requiring lifting of heavy materials or substantial exertion shall be done from ladders.

(2) **SCAFFOLDING.** OSHA 1926, Subpart L - Section 451. Scaffolds, platforms or temporary floors shall be provided for all work except that which can be done safely from the ground or similar footing.

(3) **SAFETY BELTS, LIFELINE, AND LANYARDS.** OSHA 1926, Subpart E, Section 104. Lifelines, safety belts and lanyards independently attached or attended, shall be used when

performing such work as the following when the requirements of F (1) or (2) above cannot be met.

- (a) Work on stored material in hoppers, bins, silos, tanks, or other confined spaces.
- (b) Work on hazardous slopes, structural steel, or poles; erection or dismantling of safety nets, tying reinforcing bars; and work from Boatswain's chairs, swinging scaffolds, or other unguarded locations at elevations greater than 6 feet.
- (c) Work on skips and platforms used in shafts by crews when the skip or cage does not block the opening to within 1 foot of the sides of the shaft, unless cages are provided.

PART III - SUPPLEMENTAL CONDITIONS

ARTICLE 1 – TYPES AND LIMITS OF INSURANCE

Satisfactory certificates of insurance shall be filed with Contracting Local Organization prior to commencement of any work on this contract. Insurance requirements stated below do not establish limits of the Contractor's liability.

(a) Workmen's Compensation and Employer's Liability Insurance

(1) Contractor shall provide workmen's compensation and employee's liability insurance at own expense. This insurance shall protect Contractor against all claims under applicable state workmen's compensation laws. Contractor shall also be protected against claims for injury, disease, or death of employees which, for any reason, may not fall within the provisions of a workmen's compensation law.

(2) The liability limits shall be not less than:

Workmen's Compensation	Statutory
Employer's Liability	\$500,000

(b) Comprehensive Automobile Liability Insurance

(1) Contractor shall provide comprehensive automobile liability insurance at own expense. This insurance shall be written in comprehensive form and shall protect Contractor against all claims for injuries to members of the public and damage to property of others arising from the use of motor vehicles, and shall cover operation on or off the site of all motor vehicles licensed for highway use, whether they are owned, non-owned, or hired.

(2) Policy shall list CLO as additional named insured per Article 1(f).

(3) The liability limits shall be not less than:

Bodily injury	\$250,000 each person
	\$500,000 each occurrence

Property damage	\$250,000 each occurrence
-----------------	---------------------------

(c) Comprehensive General Liability Insurance

(1) Contractor shall provide comprehensive general liability insurance at own expense. This insurance shall be written in comprehensive form and shall protect Contractor against all claims arising from injuries to persons other than his/her employees or damage to property of Contracting Local Organization or others arising out of any act or omission of Contractor or his/her agents, employees, or subcontractors. The policy shall also include protection against claims insured by usual personal injury liability coverage, such as a "protective liability" endorsement to insure the contractual liability assumed by Contractor.

(2) To the extent that Contractor's work, or work under his/her direction, may require blasting, explosive conditions, or underground operations, the comprehensive general liability coverage shall contain no exclusion relative to blasting, explosion, collapse of building, or damage to underground property.

(3) Policy shall list CLO as additional named insured per Article 1(f).

(4) The liability limits shall be not less than:

Bodily injury	\$500,000 each occurrence
---------------	---------------------------

Property damage \$250,000 each occurrence
 Aggregate \$1 million

(d) Umbrella Liability Policy. If aggregate of Comprehensive General Liability Insurance in (c)(4) above does not equal or exceed \$1 million, the Contractor shall provide umbrella liability policy at its own expense. This insurance shall protect Contractor against all claims in excess of the limits provided under the workmen's compensation and employer's liability, comprehensive automobile liability, and general liability policies. The liability limits of the umbrella liability policy shall not be less than \$1,000,000. The policy shall list CLO as additional named insured per Article 1(f).

(e) Policy Cancellation. Each policy shall contain a provision that the coverage afforded will not be canceled or materially changed until at least 30-days prior written notice has been given to the Contracting Local Organization or Contracting Officer.

(f) Additional Named Insured. The Contracting Local Organization (CLO) shall be listed as an additional named insured on Comprehensive Automobile Liability, Comprehensive General Liability, and Umbrella Liability policies.

(g) Waiver of Subrogation. All policies of insurance shall waive all rights of subrogation against the Contracting Local Organization, its officers, employees and agents.

ARTICLE 2 – SETTLEMENT OF INSURANCE CLAIMS

Losses insured under policies that include Contracting Local Organization, as a named insured, shall be adjusted with Contracting Local Organization and made payable to Contracting Local Organization as trustee for the insureds, as their interests may appear.

ARTICLE 3 – WORKERS’ COMPENSATION INSURANCE COVERAGE

Contractor shall provide worker’s compensation insurance coverage as specified below at own expense.

(a) Definitions. (1) Certificate of coverage (“certificate”)—A copy of a certificate of insurance, a certificate of authority to self-insure issued by the Texas Workers’ Compensation Commission (TWCC), or a coverage agreement (TWCC-81, TWCC-82, TWCC-83, or TWCC-84), showing statutory workers’ compensation insurance coverage for the person’s or entity’s employees providing services on a project, for the duration of the project.

(2) Duration of the project—Includes the time from the beginning of the work on the project until the Contractor’s/person’s work on the project has been completed and accepted by the Contracting Local Organization.

(3) Persons providing services on the project (“subcontractor” in §406.096, Texas Labor Code) includes all persons or entities performing all or part of the services the Contractor has undertaken to perform on the project, regardless of whether that person contracted directly with the Contractor and regardless of whether that person has employees. This includes, without limitation, independent contractors, subcontractors, leasing companies, motor carriers, owner-operators, employees of any such entity, or employees of any entity which furnishes persons to provide services on the project. “Services” include, without limitation, providing, hauling, or

delivering equipment or materials, or providing labor, transportation, or other service related to a project. "Services" does not include activities unrelated to the project, such as food/beverage vendors, office supply deliveries, and delivery of portable toilets.

(b) The Contractor shall provide coverage, based on proper reporting of classification codes and payroll amounts and filing of any coverage agreements, which meets the statutory requirements of Texas Labor Code, Section 401.011 (44) for all employees of the Contractor providing services on the project, for the duration of the project.

(c) The Contractor must provide a certificate of coverage to the Contracting Local Organization prior to being awarded the contract.

(d) If the coverage period shown on the Contractor's current certificate of coverage ends during the duration of the project, the Contractor must, prior to the end of the coverage period, file a new certificate of coverage with the Contracting Local Organization showing that coverage has been extended.

(e) The Contractor shall obtain from each person providing services on a project, and provide to the Contracting Local Organization:

(1) A certificate of coverage, prior to that person beginning work on the project, so the Contracting Local Organization will have on file certificates of coverage showing coverage for all persons providing services on the project, and

(2) No later than seven days after receipt by the Contractor, a new certificate of coverage showing extension of coverage, if the coverage period shown on the current certificate of coverage ends during the duration of the project.

(f) The Contractor shall retain all required certificates of coverage for the duration of the project and then in accordance with PART II, General Conditions, Article 37, Contractor Records.

(g) The Contractor shall notify the Contracting Local Organization in writing by certified mail or personal delivery, within 10 days after the Contractor knew or should have known, of any change that materially affects the provision of coverage of any person providing services on the project.

(h) The Contractor shall post on each project site a notice [see paragraph (l) of this Article], in the text, form and manner prescribed by the Texas Workers' Compensation Commission, informing all persons providing services on the project that they are required to be covered, and stating how a person may verify coverage and report lack of coverage.

(i) The Contractor shall contractually require each person with whom it contracts to provide services on a project, to:

(1) Provide coverage, based on proper reporting of classification codes and payroll amounts and filing of any coverage agreements, which meets the statutory requirements of Texas Labor Code, Section 401.011 (44) for all of its employees providing services on the project, for the duration of the project;

(2) Provide to the Contractor, prior to that person beginning work on the project, a certificate of coverage showing that coverage is being provided for all employees of the person providing services on the project, for the duration of the project;

(3) Provide the Contractor, prior to the end of the coverage period, a new certificate of coverage showing extension of coverage, if the coverage period shown on the current certificate of coverage ends during the duration of the project;

(4) Obtain from each other person with whom it contracts, and provide to the Contractor:

(i) a certificate of coverage, prior to the other person beginning work on the project;
and

(ii) a new certificate of coverage showing extension of coverage, prior to the end of the coverage period, if the coverage period shown on the current certificate of coverage ends during the duration of the project;

(5) Retain all required certificates of coverage on file for the duration of the project and then in accordance with PART II – General Conditions, Article 37 – Contractor Records;

(6) Notify the Contracting Local Organization in writing by certified mail or personal delivery, within 10 days after the person knew or should have known, of any change that materially affects the provision of coverage of any person providing services on the project; and

(7) Contractually require each person with whom it contracts, to perform as required by paragraphs (1) - (7), with the certificates of coverage to be provided to the person for whom they are providing services.

(j) By signing this contract or providing or causing to be provided a certificate of coverage, the Contractor is representing to the Contracting Local Organization that all employees of the Contractor who will provide services on the project will be covered by workers' compensation coverage for the duration of the project, that the coverage will be based on proper reporting of classification codes and payroll amounts, and that all coverage agreements will be filed with the appropriate insurance carrier or, in the case of a self-insured, with TWCC's Division of Self-Insurance Regulation. Providing false or misleading information may subject the Contractor to administrative penalties, criminal penalties, civil penalties, or other civil actions.

(k) The Contractor's failure to comply with any of these provisions is a breach of contract by the Contractor which entitles the Contracting Local Organization to declare the contract void if the Contractor does not remedy the breach within ten days after receipt of notice of breach from the Contracting Local Organization.

(l) Posting of Notice: "REQUIRED WORKER'S COMPENSATION COVERAGE"

"The law requires that each person working on this site or providing services related to this construction project must be covered by workers' compensation insurance. This includes persons providing, hauling, or delivering equipment or materials, or providing labor or transportation or other service related to the project, regardless of the identity of their employer or status as an employee.

Call the Texas Workers' Compensation Commission at 512/804-4345 to receive information on the legal requirement for coverage, to verify whether your employer has provided the required coverage, or to report an employer's failure to provide coverage."

ARTICLE 4 – POST-AWARD INFORMATION

(a) Contractor shall fully execute two (2) counterparts of the Contract Agreement including all the contract documents upon receipt of Notice of Award.

- (1) Copy of all insurance certificates required in Articles 1, 2, and 3 of these Supplemental Conditions.
- (2) Major equipment schedule per PART II, General Conditions, Article 8(a). A firm commitment in writing from all suppliers of equipment that will be leased shall be provided. Equipment shall be open to inspection prior to award of the contract or commencement of work to verify soundness and reliability.
- (3) Contractor's proposed workweek (days and clock hours) per PART II, General Conditions, Article 20
- (4) For a nonresident bidder who is a corporation, limited partnership, or limited liability company: a current Certificate of Authority from Texas Secretary of State, if not yet provided.
- (5) Contractor's Pollution Control Plan per Construction Specification 5, Pollution Control).

(b) Within five (5) workdays after receipt of Notice of Award, Contractor shall submit to the Contracting Officer the following post-award information:

- (1) Performance and payment bonds as specified in Article 13 of these Supplemental Conditions.
- (2) List of proposed subcontractors required in PART II, General Conditions, Article 21(a).

ARTICLE 5 – PERFORMANCE OF WORK BY CONTRACTOR

The Contractor shall perform on the site, and with its own organization, work equivalent to at least twenty (20) percent of the total amount of work to be performed under the Contract. This percentage may be reduced by a supplemental agreement to this contract if, during the performance of the work, the Contractor requests a reduction and the Contracting Officer determines that the reduction would be to the advantage of the Contracting Local Organization.

ARTICLE 6 – COMMENCEMENT, PROSECUTION, AND COMPLETION OF WORK

(a) Contractor shall be required to:

- (1) Commence work under this contract within ten (10) calendar days from the date of receipt of written Notice to Proceed. Prosecute the work diligently; and
- (b) Complete the entire work ready for use not later than one-hundred-twelve (112) calendar days from receipt of Notice to Proceed. The ten calendar days for mobilization is included in the one-hundred-twelve calendar days.
- (c) The time stated for completion shall include final cleanup of the premises.

ARTICLE 7 – VENUE

This contract shall be governed, construed and interpreted under the laws of the State of Texas. This contract is performable in Navarro County, Texas. The Contracting Local Organization has domicile in Navarro County, Texas, and any legal action must be filed in Navarro County, Texas.

ARTICLE 8 – WAGES / BENEFITS**8.1 General**

Contractor shall pay or cause to be paid, without cost or expense to Contracting Local Organization, all Social Security, Unemployment and Federal Income Withholding Taxes of all such employees, and all such employees shall be paid wages and benefits as required by Federal and/or State law (including but not restricted to unemployment compensation coverage) and per wage rates requirements in Article 8.2 below. In accordance with Texas Labor Code §61.012, Contractor shall post in conspicuous places in the workplace notices indicating the paydays.

8.2 Laborers and Mechanics – Prevailing Wage Rates

(a) This contract requires the Contractor and any of his/her subcontractors at any tier to pay prevailing wage rates as specified in this article and to follow requirements contained in Texas Government Code, Chapter 2258, Prevailing Wage Rates.

(b) A copy of the Prevailing Wage Rates Determination under the Davis-Bacon Act, as amended (40 USC 3141-3148) that must be followed is included in PART VI of the contract.

(c) A worker employed or working upon the site of the work shall be paid the full amount of wages and bona fide fringe benefits (or cash equivalents thereof) computed at rates not less than those contained in the Prevailing Wage Rates Determination for regular work and for legal holiday and overtime work, regardless of any contractual relationship which may be alleged to exist between the Contractor and such workers. "Worker" includes laborers or mechanics.

(d) Workers shall be paid not less than the appropriate wage rate and fringe benefits in the wage determination for the classification of work actually performed, without regard to skill. Those performing work in more than one classification may be compensated at the rate specified for each classification for the time actually worked therein; provided that the employer's payroll records accurately set forth the time spent in each classification in which work is performed.

(e) The wage determination shall be posted at all times by the Contractor and subcontractors at the site of the work in a prominent and accessible place where it can be easily seen by workers.

(f) Whenever the minimum wage rate prescribed in the contract for a class of laborers or mechanics includes a fringe benefit which is not expressed as an hourly rate, the Contractor shall either pay the benefit as stated in the wage determination or shall pay another bona fide fringe benefit or an hourly cash equivalent thereof.

(g) The Contractor or subcontractor shall insert in any subcontracts this Article 8, and also a clause requiring subcontractors to include Article 8 in any lower tier subcontracts. The Prime Contractor shall be responsible for compliance by any subcontractor or lower tier subcontractor with this article.

(h) Payroll records. A Contractor and subcontractor shall keep a record showing: (i) the name and occupation of each worker (includes a laborer or mechanic) employed by the Contractor or subcontractor in the construction of the public work; and (ii) the actual per diem wages paid to each worker. The record shall be open at all reasonable hours to inspection by the officers and agents of the Contracting Local Organization and others as required by PART II, General Conditions, Article 37 (Contractor Records).

ARTICLE 9 – ETHICS / CONFLICTS OF INTEREST

(a) Texas Local Government Code Chapter 171 provisions apply to award of this contract.

(b) A bidder and/or Contractor shall not offer or accept gifts or anything of value nor enter into any business arrangement with any employee, official or agent of the Contracting Local Organization or USDA-NRCS.

ARTICLE 10 – PROTESTS

(a) Any actual or prospective bidder, offeror, proposer, or contractor who is aggrieved in connection with the solicitation, evaluation, or award of a contract may formally protest to the Contracting Officer. Such protests must be in writing and received by the Contracting Officer within vi working days after such aggrieved person knows, or should have known, of the occurrence of the action which is protested. Formal protests must conform to the requirements of this article and subsection (c) of this article, and shall be resolved in accordance with the procedure set forth in subsections (d) and (e) of this article. Copies of the protest must be mailed or delivered by the protesting person to the project manager, if any, and other interested persons. For the purposes of this section, "interested persons" means all vendors who have submitted bids or proposals for the contract involved.

(b) In the event of a timely protest or appeal under this section, the Contracting Local Organization shall not proceed further with the solicitation or with the award of the contract unless the Contracting Officer makes a written determination that the award of a contract without delay is necessary to protect substantial interests of the state.

(c) A formal protest must be sworn and notarized and contain:

- (1) a specific identification of the statutory or regulatory provision(s) that the action complained of is alleged to have violated;
- (2) a specific description of each act alleged to have violated the statutory or regulatory provision(s) identified in paragraph (1) of this subsection;
- (3) a precise statement of the relevant facts;
- (4) an identification of the issue or issues to be resolved;
- (5) argument and authorities in support of the protest; and
- (6) a statement that copies of the protest have been mailed or delivered to other identifiable interested persons.

(d) The Contracting Officer may settle and resolve the dispute concerning the solicitation or award of a contract by mutual agreement with the protesting person. The Contracting Officer may solicit written responses to the protest from other interested persons.

(e) If the protest is not resolved by mutual agreement, the Contracting Officer will issue a written determination on the protest.

(1) If the Contracting Officer determines that no violation of rules or statutes has occurred, he or she shall inform the protesting person and other interested persons by letter which sets forth the reasons for the determination.

(2) If the Contracting Officer determines that a violation of the rules or statutes has occurred in a case where a contract has not been awarded, he or she shall inform the protesting person and other interested persons by letter that sets forth the reasons for the determination and the appropriate remedial action.

(3) If the Contracting Officer determines that a violation of the rules or statutes has occurred in a case where a contract has been awarded, he or she shall inform the protesting person and other interested persons by letter which sets forth the reasons for the determination, and the appropriate remedial action, which may include ordering the contract void.

(f) After the Contracting Officer's determination has been made, the aggrieved person or interested persons may request reconsideration of the Contracting Officer's determination to be made by the Navarro Soil and Water Conservation District Vice Chairman or his/her designee. Such request must be in writing and must be received in the Board office no later than ten working days after the date of the Contracting Officer's determination, which shall be calculated from the date the Contracting Officer's letter is hand-delivered, delivered by a nationally recognized courier service, or mailed by certified or registered mail. The request shall be limited to review of the Contracting Officer's determination. Copies of the request must be mailed or delivered by the aggrieved person to other interested persons. The request must contain an affidavit that such copies have been provided.

(g) The Navarro Soil and Water Conservation District Vice Chairman shall issue a final determination on the protest within 15 days after receipt of the aggrieved person's request for reconsideration.

(h) A decision issued in writing by the Navarro Soil and Water Conservation District Vice Chairman in response to a request for reconsideration shall be the final administrative action of the Board.

(i) Unless good cause for delay is shown or the Contracting Officer or Navarro Soil and Water Conservation District Vice Chairman determines that a protest or appeal raises issues significant to procurement practices or procedures, a protest or appeal that is not filed timely will not be considered.

(j) In the event of a protest, all documents collected by the Navarro SWCD Board as part of a solicitation, evaluation, and/or award of a contract shall be retained by the Board for a period of four years to include the current fiscal year and three additional fiscal years.

ARTICLE 11 – DISPUTES / ALTERNATIVE DISPUTE RESOLUTION (ADR)

This article supplements PART II, General Conditions, Article 6 – Claims.

11.1 Claims

(a) The Contracting Local Organization’s policy is to try to resolve all contractual issues in controversy by mutual agreement at the Contracting Officer’s level. Reasonable efforts should be made to resolve controversies prior to the submission of a claim. Use of ADR procedures to the maximum extent practicable is encouraged.

(b) Initiation of a claim. (1) Contractor claims shall be submitted, in writing, to the Contracting Officer for a decision no later than the 180th day after accrual of a claim. The claim must state with particularity the nature of the breach, the amount the Contractor seeks as damages, and the legal theory of recovery. The Contracting Officer shall document the contract file with evidence of the date of receipt of any submission from the Contractor deemed to be a claim by the Contracting Officer. The Contracting Officer must assert, in a writing delivered to the Contractor, any counterclaim not later than the 90th day after the date of receipt of Contractor’s written claim.

(2) The Contracting Local Organization shall issue a written decision on any Contracting Local Organization claim initiated against a Contractor no later than the 180th day after accrual of the claim. This time period shall not apply to a Contracting Local Organization claim based on a Contractor claim involving fraud.

(c) Contractor certification. Contractor shall provide the certification specified below when submitting any claim exceeding \$100,000, or regardless of the amount claimed when using ADR procedures. The certification requirement does not apply to issues in controversy that have not been submitted as all or part of a claim. The certification may be executed by any person duly authorized to bind the Contractor with respect to the claim. The certification shall state as follows:

“I certify that the claim is made in good faith; that the supporting data are accurate and complete to the best of my knowledge and belief; that the amount requested accurately reflects the contract adjustment for which the Contractor believes the Contracting Local Organization is liable; and that I am duly authorized to certify the claim on behalf of the Contractor.”

(d) The Contracting Local Organization shall pay interest on a Contractor’s claim on the amount found due and unpaid from the date that the Contracting Officer receives the claim (certified if required by Article 11.1(c) above); or payment otherwise would be due, if that date is later, until the date of payment. If a claim has a defective certification, interest shall be paid from the date that the Contracting Local Organization receives a proper certification. Amount of interest due will be per Texas and local law and regulation.

11.2 Alternative Dispute Resolution (ADR)

(a) The objective of using ADR procedures is to increase the opportunity for relatively inexpensive and expeditious resolution of issues in controversy. Essential elements of ADR include:

- (1) Existence of an issue in controversy,
- (2) A voluntary election by both parties to participate in the ADR process,
- (3) An agreement on alternative procedures and terms to be used in lieu of formal litigation,

(4) Participation in the process by officials of both parties who have the authority to resolve the issue in controversy, and

(5) Certification by the Contractor in accordance with Article 11.1(c) when using ADR procedures to resolve all or part of a claim.

(b) If either party rejects a request for ADR from the other party, the rejecting party shall inform the other party in writing of the specific reasons for rejecting the request, including but not limited to why ADR procedures are inappropriate for the resolution of the dispute.

(c) ADR procedures may be used at any time that the Contracting Officer has authority to resolve the issue in controversy. If a claim has been submitted, ADR procedures may be applied to all or a portion of the claim. When ADR procedures are used subsequent to the issuance of a Contracting Officer's final decision, their use does not constitute a reconsideration of the final decision.

(d) When appropriate, a neutral person may be used to facilitate resolution of the issue in controversy using the procedures chosen by the parties.

(e) The rights of Contracting Local Organization and Contractor to exercise such rights or remedies as either party may otherwise have under the contract or by laws or regulations in respect of any claims, disputes, and other issues in controversy are not affected by action taken under this Article.

(f) ADR procedures must be consistent with Chapter 154, Texas Civil Practice and Remedies Code, and Chapter 2009, Texas Government Code, Alternative Dispute Resolution for Use by Governmental Bodies.

11.3 Definitions

(a) Accrual of a claim occurs on the date when all events, which fix the alleged liability of either the Contracting Local Organization or the Contractor and permit assertion of the claim, were known or should have been known. For liability to be fixed, some injury must have occurred. However, monetary damages need not have been incurred.

(b) Alternative dispute resolution (ADR) means any procedure or combination of procedures voluntarily used to resolve issues in controversy without the need to resort to litigation. These procedures may include, but are not limited to, assisted settlement negotiations, conciliation, facilitation, mediation, fact-finding, mini-trials, and arbitration.

(c) Claim as used in this Article means a written demand or written assertion by one of the contracting parties seeking as a matter of right, the payment of money in a sum certain, the adjustment or interpretation of contract terms, or other relief arising under or relating to the contract. A claim arising under a contract, unlike a claim relating to that contract, is a claim that can be resolved under a contract clause that provides for the relief sought by the claimant. However, a written demand or written assertion by the contractor seeking the payment of money exceeding \$100,000 is not a claim under this Article until certified as required by Article 11.1(c) above. A voucher, invoice, or other routine request for payment that is not in dispute when submitted is not a claim. The submission may be converted to a claim, by written notice to the Contracting Officer within time limits in section 11.1(b) of this Article, if it is disputed either as to liability or amount or is not acted upon in a reasonable time.

(d) Defective certification as used in this Article means a certificate which alters or otherwise deviates from the language in this Article or which is not executed by a person duly authorized to bind the Contractor with respect to the claim. Failure to certify shall not be deemed to be a defective certification.

(e) Issue in controversy means a material disagreement between the Contracting Local Organization and the Contractor which:

- (1) May result in a claim, or
- (2) Is all or part of an existing claim.

(f) Misrepresentation of fact as used in this Article means a false statement of substantive fact, or any conduct which leads to the belief of a substantive fact material to proper understanding of the matter in hand, made with intent to deceive or mislead.

(g) Neutral person as used in this Article means an impartial third party, who serves as a mediator, fact finder, or arbitrator, or otherwise functions to assist the parties to resolve the issues in controversy. A neutral person may be a permanent or temporary officer or employee of the Contracting Local Organization, or the Federal government, or any other individual who is acceptable to the parties. A neutral person shall have no official, financial, or personal conflict of interest with respect to the issues in controversy, unless such interest is fully disclosed in writing to all parties and all parties agree that the neutral person may serve. An "impartial third party" must possess the qualifications required under Section 154.052, Texas Civil Practice and Remedies Code.

ARTICLE 12 – INDEMNIFICATION CLAUSE

The Contractor shall defend, indemnify, and hold harmless the Contracting Local Organization, all of its officers, agents and employees from and against all claims, actions, suits, demands, proceedings, costs, damages, and liabilities, arising out of, connected with, or resulting from any acts or omissions of Contractor or any agent, employee, subcontractor, or supplier of Contractor in the execution of performance of this contract.

ARTICLE 13 – PERFORMANCE AND PAYMENT BONDS

13.1 General

(a) This contract requires performance and payment bonds as outlined in 13.2 below. Such bonds are due within five (5) workdays after receipt of Notice of Award (see Article 4 of these Supplemental Conditions). The Contracting Local Organization will attach to the Notice of Award the bond forms to be used.

(b) Bonds shall be made payable to: Navarro SWCD, 4323 West Highway 22, Corsicana, TX 75110.

(c) Bonds are subject to requirements stated in this Article and requirements of Texas Government Code, Chapter 2253, Public Work Performance and Payment Bonds, and must be executed by a corporate surety in accordance with Texas Insurance Code, Chapter 3503 (Surety Bonds and Related Instruments), Subchapter A.

13.2 Performance and Payment Bonds—Construction

(a) *Definitions.* As used in this clause-- "Contract price" means the award price of the contract. "Government" means the Contracting Local Organization.

(b) The successful offeror shall be required to furnish performance and payment bonds to the Contracting Officer as follows:

(1) *Performance Bond:*

(i) The penal amount of performance bond shall be 100 percent of the original contract price.

(ii) The Government may require additional performance bond protection when the contract price is increased. The increase in protection shall generally equal 100 percent of the increase in contract price.

(iii) The Government may secure additional protection by directing the Contractor to increase the penal amount of the existing bond or to obtain an additional bond.

(2) *Payment Bond:*

(i) The penal amount of payment bond shall be 100 percent of the original contract price.

(ii) The Government may require additional performance bond protection when the contract price is increased. The increase in protection shall generally equal 100 percent of the increase in contract price.

(iii) The Government may secure additional protection by directing the Contractor to increase the penal sum of the existing bond or to obtain an additional bond.

(c) The Contractor shall furnish all executed bonds, including any necessary reinsurance agreements, to the Contracting Officer, within the time period specified in 13.1 above.

(d) A bond may be executed only by a corporate surety company that is authorized and admitted to write surety bonds in the State of Texas.

(e) For both the Performance bond and Payment bond, the surety must (i) hold a certificate of authority from the United States Secretary of the Treasury to qualify as a surety on obligations permitted or required under federal law; or (ii) have obtained reinsurance for any liability in excess of \$1,000,000 from a reinsurer that is an authorized reinsurer in the State of Texas or is a holder of a certificate of authority from the United States Secretary of the Treasury to qualify as a surety or reinsurer on obligations permitted or required under federal law. U.S. Treasury Department Circular 570 is published in the *Federal Register* and lists Treasury approved surety companies and their underwriting limitations.

(f) All bonds signed by an agent must be accompanied by a certified copy of such agent's authority to act.

(g) A bond required under this Article must clearly and prominently display on the bond or on an attachment to the bond: (1) the name, mailing address, physical address, and telephone number, including the area code, of the surety company to which any notice of claim should be sent; or (2) the toll-free telephone number maintained by the Texas Department of Insurance under Subchapter B, Chapter 521, Insurance Code, and a statement that the address of the surety company to which any notice of claim should be sent may be obtained from the Texas Department of Insurance by calling the toll-free telephone number.

ARTICLE 14 – EQUAL OPPORTUNITY (FEDERALLY ASSISTED CONSTRUCTION)

During the performance of this contract, the Contractor agrees as follows:

(a) The Contractor will not discriminate against any employee or applicant for employment because of race, color, religion, sex, sexual orientation, gender identity, or national origin. The Contractor will take affirmative action to ensure that applicants are employed, and that employees are treated during employment without regard to their race, color, religion, sex, sexual orientation, gender identity, or national origin. Such action shall include, but not be limited to the following: Employment upgrading, demotion or transfer, recruitment or recruitment advertising; layoff or termination; rates of pay or other forms of compensation; and selection for training, including apprenticeship. The Contractor agrees to post in conspicuous places, available to employees and applicants for employment, notices to be provided setting forth the provisions of this Equal Opportunity (Federally Assisted Construction) clause.

(b) The Contractor will, in all solicitations or advertisements for employees placed by or on behalf of the Contractor, state that all qualified applicants will receive considerations for employment without regard to race, color, religion, sex, sexual orientation, gender identity, or national origin.

(c) The Contractor will send to each labor union or representative of workers, with which he/she has a collective bargaining agreement or other contract or understanding, a notice to be provided advising the said labor union or workers' representatives of the Contractor's commitments under this section, and shall post copies of the notice in conspicuous places available to employees and applicants for employment.

(d) The Contractor will comply with all provisions of Executive Order No. 11246 of September 24, 1965, and of the rules, regulations, and relevant orders of the Secretary of Labor.

(e) The Contractor will furnish all information and reports required by Executive Order No. 11246 of September 24, 1965, and by the rules, regulations, and orders of the Secretary of Labor, or pursuant thereto, and will permit access to his/her books, records, and accounts by the administering agency and the Secretary of Labor for purposes of investigation to ascertain compliance with such rules, regulations, and orders.

(f) In the event of the Contractor's noncompliance with the nondiscrimination clause of this contract or with any of the said rules, regulations, or orders, this contract may be canceled, terminated, or suspended, in whole or in part, and the Contractor may be declared ineligible for further Government contracts or federally assisted construction contracts in accordance with procedures authorized in Executive Order No. 11246 of September 24, 1965, and such other sanctions may be imposed and remedies invoked as provided in Executive Order No. 11246 of September 24, 1965, or by rule, regulations, or order of the Secretary of Labor, or as provided by law.

(g) The Contractor will include this Equal Opportunity (Federally Assisted Construction) clause in every subcontract or purchase order, unless exempted by the rules, regulations, or orders of the Secretary of Labor issued pursuant to section 204 of Executive Order No. 11246 of September 24, 1965, so that such provisions will be binding upon each subcontractor or vendor. The Contractor will take such action with respect to any subcontract or purchase order as the administering agency may direct as a means of enforcing such provisions, including sanctions for noncompliance. Provided, however, in the event a Contractor becomes involved in, or is

threatened with, litigation with a subcontractor or vendor as a result of such direction by the administering agency the Contractor may request the United States to enter into such litigation to protect the interests of the United States.

ARTICLE 15 – NOTICE TO PROSPECTIVE FEDERALLY ASSISTED CONSTRUCTION CONTRACTORS

(a) A Certification of Nonsegregated Facilities (included in PART I – General Provisions, Subpart C, Bid Forms, Exhibit H, Section F) must be submitted prior to the award of a federally assisted construction contract which is not exempt from the provisions of the Equal Opportunity clause (Article 14 of these Supplemental Conditions).

(b) Contractors receiving federally assisted construction contract awards not exempt from the provisions of the Equal Opportunity clause will be required to forward the following notice to prospective subcontractors for supplies and construction contracts where the subcontracts and are not exempt from the provisions of the Equal Opportunity clause (Article 14 of these Supplemental Conditions).

Notice to Prospective Subcontractors of Requirement for Certification of Nonsegregated Facilities

(a) A Certification of Nonsegregated Facilities shown below must be submitted prior to the award of a subcontract which is not exempt from the provisions of the Equal Opportunity clause.

(b) Contractors receiving subcontract awards not exempt from the provisions of the Equal Opportunity clause will be required to forward this notice to prospective subcontractors for supplies and construction contracts where the subcontracts are not exempt from the provisions of the Equal Opportunity clause.

Certification of Nonsegregated Facilities

[Applicable to federally assisted construction contracts and related subcontracts not exempt from the Equal Opportunity clause (Article 14 of PART III - Supplemental Conditions)]

The federally assisted construction Contractor certifies they do not maintain or provide for their employees any segregated facilities at any of their establishments, and that they do not permit their employees to perform services at any location, under their control, where segregated facilities are maintained. The federally assisted construction Contractor certifies further that they will not maintain or provide for their employees any segregated facilities at any of their establishments, and that, they will not permit their employees to perform services at any location, under their control, where segregated facilities are maintained. The federally assisted construction Contractor agrees that a breach of this section is a violation of the Equal Opportunity clause in this contract. As used in this caption, the term “segregated facilities” means any waiting rooms, work areas, restrooms, washrooms, restaurants and other eating areas, time clocks, locker

rooms and other storage or dressing areas, parking lots, drinking fountains, recreation or entertainment areas, transportation, and housing facilities provided for employees which are segregated by explicit directive or are in fact segregated on the basis of race, color, religion, sex, sexual orientation, gender identity, or national origin or because of habit, local custom, or otherwise. The federally assisted construction Contractor agrees that (except where they have obtained identical certifications from proposed subcontractors for specific time periods) they will obtain identical certifications from proposed subcontractors prior to the award of subcontracts which are not exempt from the provisions of the Equal Opportunity clause, and that they will retain such certifications in their files.

NOTE: Penalty for making false statements in offers is prescribed in 18 U.S.C. 1001.

ARTICLE 16 – STANDARD FEDERAL EQUAL EMPLOYMENT OPPORTUNITY CONSTRUCTION CONTRACT SPECIFICATIONS (EXECUTIVE ORDER 11246)

(1) As used in these specifications:

- (a) "Covered area" means the geographical area described in the solicitation from which this contract resulted.
- (b) "Director" means Director, Office of Federal Contract Act Compliance Program, United States Department of Labor, or any person to whom the Director delegates authority.
- (c) "Employer identification number" means the Federal Social Security number used on the Employer's Quarterly Federal Tax Return, U.S. Treasury Department Form 94 1.
- (d) "Minority" includes: (i) Black (all persons having origins in any of the Black African racial groups not of Hispanic origin); (ii) Hispanic (all persons of Mexican, Puerto Rican, Cuban Central or South American or other Spanish Culture or origin, regardless of race); (iii) Asian and Pacific Islander (all persons having origins in any of the original peoples of the Far East, Southeast Asia, the Indian Subcontinent, or the Pacific Islands); and (iv) American Indian or Alaskan Native (all persons having origins in any of the original peoples of North America and maintaining identifiable tribal affiliations through membership and participation or community identification).

(2) Whenever the Contractor, or any Subcontractor at any tier, subcontracts a portion of the work involving any construction trade, it shall physically include in each subcontract, in excess of \$10,000, the provisions of these specifications and the Notice which contains the applicable goals for minority and female participation which is set forth in the solicitations from which the contract resulted.

(3) If the Contractor is participating (pursuant to 41 CFR 60-4.5) in a Hometown Plan approved by the U.S. Department of Labor in the covered area either individually or through an association, its affirmative action obligations on all work in the Plan area (including goals and timetables) shall be in accordance with that Plan for those trades which have unions participating in the Plan. Contractors must be able to demonstrate their participation in and compliance with the provisions of any such Hometown Plan. Each Contractor or Subcontractor participating in an

approved Plan is individually required to comply with its obligations under the EEO Clause, and to make a good faith effort to achieve each goal under the Plan in each trade in which it has employees. The overall good faith performance by other Contractors or Subcontractors toward a goal in an approved Plan does not excuse any covered Contractors or Subcontractors failure to take good faith efforts to achieve the Plan goals and timetables.

(4) The Contractor shall implement the specific affirmative action standards provided in Paragraphs (7)(a) through (7)(p) of these specifications. The goals set forth in the solicitation from which this contract resulted are expressed as percentages of the total hours of employment and training of minority and female utilization that the Contractor should reasonably be able to achieve in each construction trade in which it has employees in the covered area. Covered construction contractors performing construction work in geographical areas where they do not have a Federal or Federally assisted construction contract shall apply the minority and female goals established for the geographic area where the work is being performed. Goals are published periodically in the *Federal Register* in notice form and such notices may be obtained from any Office of Federal Contract Compliance Programs or from Federal Procurement Contracting Officers. The Contractor is expected to make substantially uniform progress in meeting its goals in each craft during the period specified.

Notice for IFB No. NSWCD-17-RCS31-02

- (a) Covered Area is Navarro County, Texas.
- (b) Goal for Female Participation: 6.9 percent (all trades)
- (c) Goal for Minority Participation: Navarro County: 17.2 percent (all trades)
- (d) Goals are expressed in percentage terms for the Contractor's aggregate workforce in each trade on all construction work in the covered area.

(5) Neither the provisions of any collective bargaining agreement, nor the failure by a union with whom the Contractor has a collective bargaining agreement, to refer either minorities or women shall excuse the Contractor's obligations under the specifications, Executive Order 11246, or the regulations promulgated pursuant thereto.

(6) In order for the non-working training hours of apprentices and trainees to be counted in meeting the goals, such apprentices and trainees must be employed by the Contractor during the training period, and the Contractor must have made a commitment to employ the apprentices and trainees at the completion of their training, subject to the availability of employment opportunities. Trainees must be trained pursuant to training programs approved by the U.S. Department of Labor.

(7) The Contractor shall take specific affirmative actions to ensure equal employment opportunity. The evaluation of the Contractor's compliance with these specifications shall be based upon its effort to achieve maximum results from its actions. The Contractor shall document these efforts fully, and shall implement affirmative action steps at least as extensive as the following:

- (a) Ensure and maintain a working environment free of harassment, intimidation and coercion at all sites, and in all facilities at which the Contractor's employees are assigned to work. The Contractor, where possible, will assign two or more women to each construction project. The Contractor shall specifically ensure that all foremen, superintendents, and other on-site supervisory personnel are aware of and carry out the Contractor's obligation to maintain such a working environment, with specific attention to minority or female individuals working at such sites or in such facilities.
- (b) Establish and maintain a current list of minority and female recruitment sources, provide written notification to minority and female recruitment sources and to community organizations when the Contractor or its unions have employment opportunities available, and maintain a record of the organizations' responses.
- (c) Maintain a current file of the names, addresses and telephone numbers of each minority and female off-the-street applicant and minority or female referral from a union, a recruitment source or community organization and of what action was taken with respect to each such individual. If such individual was sent to the union hiring hall for referral and was not referred back to the Contractor by the union, or, if referred, not employed by the Contractor, this shall be documented in the file with the reason therefor, along with whatever additional actions the Contractor may have taken.
- (d) Provide immediate written notification to the Director when the union or unions with which the Contractor has a collective bargaining agreement has not referred to the Contractor a minority person or woman sent by the Contractor; or, when the Contractor has other information that the union referral process had impeded the Contractor's efforts to meet its obligations.
- (e) Develop on-the-job training opportunities and/or participate in training programs for the area which expressly include minorities and women, including upgrading programs and apprenticeship and trainee programs relevant to the Contractor's employment needs, especially those programs funded or approved by the Department of Labor. The Contractor shall provide notice of these programs to the sources compiled under paragraph (7)(b) above.
- (f) Disseminate the Contractor's EEO policy by providing notice of the policy to unions and training programs and requesting their cooperation in assisting the Contractor in meeting its EEO obligations; by including it in any policy manual and collective bargaining agreement; by publicizing it in the company newspaper, annual report, etc.; by specific review of the policy with all management personnel and with all minority and female employees at least once a year; and by posting the company EEO policy on bulletin boards accessible to all employees at each location where construction work is performed.
- (g) Review, at least annually, the company's EEO policy and affirmative action obligations under these specifications with all employees having any responsibility for hiring, assignment, layoff, termination, or other employment decisions, including specific review of these items with on-site supervisory personnel such as Superintendents, General Foremen, etc., prior to the initiation of construction work at any job site. A written record shall be made and maintained identifying the time and place of these

meetings, persons attending, subject matter discussed, and disposition of the subject matter.

- (h) Disseminate the Contractor's EEO policy externally by including it in any advertising in the news media, specifically including minority and female news media, and providing written notification to and discussing the Contractor's EEO policy with other contractors and subcontractors with whom the Contractor does or anticipates doing business.
- (i) Direct its recruitment efforts, both oral and written, to minority, female, and community organizations, to schools with minority and female students and to minority and female recruitment and training organizations serving the Contractor's recruitment area and employment needs. Not later than one month prior to the date for the acceptance of the applications for apprenticeship or other training by any recruitment sources the Contractor shall send written notification, to organizations such as the above, describing the openings, screening procedure, and tests to be used in the selection process.
- (j) Encourage present minority and female employees to recruit other minority persons and women and, where reasonable, provide after school, summer and vacation employment to minority and female youth both on the site and in other areas of a Contractor's workforce.
- (k) Validate all tests and other selection requirements where there is an obligation to do so under 41 CFR Part 60-3.
- (l) Conduct, at least annually, an inventory and evaluation at least of all minority and female personnel for promotional opportunities and encourage these employees to seek or to prepare for, through appropriate training, etc., such opportunities.
- (m) Ensure that seniority practices, job classifications, work assignments, and other personnel practices do not have a discriminatory effect by continually monitoring all personnel and employment related activities to ensure that the EEO policy and the Contractor's obligations under these specifications are being carried out.
- (n) Ensure that all facilities and company activities are nonsegregated except that separate or single-user toilet and necessary changing facilities shall be provided to assure privacy between the sexes.
- (o) Document and maintain a record of all solicitations of offers for subcontracts from minority and female construction contractors and suppliers, including circulation of solicitations to minority and female contractor associations and other business associations.
- (p) Conduct a review, at least annually, of all supervisors' adherence to and performance under the Contractor's EEO policies and affirmative action obligations.

(8) Contractors are encouraged to participate in voluntary associations which assist in fulfilling one or more of the affirmative action obligations [paragraphs (7)(a) through (7)(p)]. The efforts of a contractor association, joint contractor-union, contractor-community, or other similar group of which the Contractor is a member and participant, may be asserted as fulfilling any one or more of its obligations under paragraphs (7)(a) through (7)(p) of the specifications, provided that the Contractor actively participates in the group, makes every effort to assure that the group has a positive impact on the employment of minorities and women in the industry, ensures that the concrete benefits of the program are reflected in the Contractor's minority and female workforce

participation, makes a good faith effort to meet its individual goals and timetables, and can provide access to documentation which demonstrates the effectiveness of actions taken on behalf of the Contractor. The obligation to comply, however, is the Contractor's and failure of such a group to fulfill an obligation shall not be a defense for the Contractor's noncompliance.

(9) A single goal for minorities and a separate single goal for women have been established. The Contractor, however, is required to provide equal employment opportunity and to take affirmative action for all minority groups, both male and female, and all women, both minority and nonminority. Consequently, the Contractor may be in violation of the Executive Order if a particular group is employed in a substantially disparate manner (for example, even though the Contractor has achieved its goals for women generally, the Contractor may be in violation of the Executive Order if a specific minority group of women is underutilized).

(10) The Contractor shall not use the goals and timetables or affirmative action standards to discriminate against any person because of race, color, religion, sex, sexual orientation, gender identity, or national origin.

(11) The Contractor shall not enter into any subcontract with any person or firm debarred from Government contracts pursuant to Executive Order 11246.

(12) The Contractor shall carry out such sanctions and penalties for violation of these specifications and of the Equal Opportunity Clause, including suspension, termination, and cancellation of existing subcontracts as may be imposed or ordered pursuant to Executive Order 11246, as amended, and its implementing regulations, by the Office of Federal Contract Compliance Programs. Any Contractor who fails to carry out such sanctions and penalties shall be in violation of these specifications and Executive Order 11246, as amended.

(13) The Contractor, in fulfilling its obligations under these specifications, shall implement specific affirmative action steps, at least as extensive as those standards prescribed in paragraph (7) of these specifications, so as to achieve maximum results from its efforts to ensure equal employment opportunity. If the Contractor fails to comply with the requirements of the Executive Order, the implementing regulations, or these specifications, the Director shall proceed in accordance with 41 CFR 60-4.8.

(14) The Contractor shall designate a responsible official to monitor all employment related activity to ensure that the company EEO policy is being carried out, to submit reports relating to the provisions hereof as may be required by the Government, and to keep records. Records shall at least include for each employee the name, address, telephone numbers, construction trade, union affiliation if any, employee identification number when assigned, social security number, race, sex, status (e.g., mechanic, apprentice, trainee, helper, or laborer), dates of changes in status, hours worked per week in the indicated trade, rate of pay, and locations at which the work was performed. Records shall be maintained in an easily understandable and retrievable form; however, to the degree that existing records satisfy this requirement, Contractors shall not be required to maintain separate records.

(15) Nothing herein provided shall be construed as a limitation upon the application of other laws which establish different standards of compliance or upon the application of requirements

for the hiring of local or other area residents (e.g., those under the Public Works Employment Act of 1977 and the Community Development Block Grant Program).

ARTICLE 17 – CERTIFICATION REGARDING DEBARMENT, SUSPENSION, INELIGIBILITY AND VOLUNTARY EXCLUSION—LOWER TIER COVERED TRANSACTIONS [*Applicable to offers of \$25,000 or more*]

Per Contractor's certification given in PART I, Subpart C, Exhibit H, Section G, this Article shall be included, without modification, in all lower tier covered transactions (subcontracts) and in all solicitations for lower tier covered transactions.

(a) Instructions for Certification

(1) By signing and submitting this proposal, the prospective lower tier participant is providing the certification set out below.

(2) The certification in this clause is a material representation of fact upon which reliance was placed when this transaction was entered into. If it is later determined that the prospective lower tier participant knowingly rendered an erroneous certification, in addition to other remedies available to the Federal Government, the department or agency with which this transaction originated may pursue available remedies, including suspension and/or debarment.

(3) The prospective lower tier participant shall provide immediate written notice to the person to which this proposal is submitted if at any time the prospective lower tier participant learns that its certification was erroneous when submitted or had become erroneous by reason of changed circumstances.

(4) The terms herein are as defined in 2 CFR Part 180, OMB Guidelines to Agencies on Governmentwide Debarment and Suspension (Nonprocurement).

(5) The prospective lower tier participant agrees by submitting this proposal that, should the proposed covered transaction be entered into, it shall not knowingly enter into any lower tier covered transaction with a person who is proposed for debarment under 48 Code of Federal Regulations (CFR) part 9, subpart 9.4, debarred, suspended, declared ineligible, or voluntarily excluded from participation in this covered transaction, unless authorized by the department or agency with which this transaction originated.

(6) The prospective lower tier participant further agrees by submitting this proposal that it will include this clause titled "Certification Regarding Debarment, Suspension, Ineligibility and Voluntary Exclusion—Lower Tier Covered Transactions," without modification, in all lower tier covered transactions of \$25,000 or more and in all solicitations for lower tier covered transactions.

(7) A participant in a covered transaction may rely upon a certification of a prospective participant in a lower tier covered transaction that it is not proposed for debarment under 48 CFR part 9, subpart 9.4, debarred, suspended, ineligible, or voluntarily excluded from covered transactions, unless it knows that the certification is erroneous. A participant may decide the method and frequency by which it determines the eligibility of its principals. Each participant may, but is not required to, check the Office of Federal Compliance Programs electronic roster at the System for Award Management (SAM) website: www.sam.gov.

(8) Nothing contained in the foregoing shall be construed to require establishment of a system of records in order to render in good faith the certification required by this clause. The knowledge and information of a participant is not required to exceed that which is normally possessed by a prudent person in the ordinary course of business dealings.

(9) Except for transactions authorized under paragraph (5) of these instructions, if a participant in a covered transaction knowingly enters into a lower tier covered transaction with a person who is proposed for debarment under 48 CFR part 9, subpart 9.4, suspended, debarred, ineligible, or voluntarily excluded from participation in this transaction, in addition to other remedies available to the Federal Government, the department or agency with which this transaction originated may pursue available remedies, including suspension and/or debarment.

**Certification Regarding Debarment, Suspension, Ineligibility and
Voluntary Exclusion – Lower Tier Covered Transactions**

(1) The prospective lower tier participant certifies, by submission of this proposal, that neither it nor its principals is presently debarred, suspended, proposed for debarment, declared ineligible, or voluntarily excluded from participation in this transaction by any Federal department or agency.

(2) Where the prospective lower tier participant is unable to certify to any of the statements in this certification, such prospective participant shall attach an explanation to this offer.

NOTE: Penalty for making false statements in offers is prescribed in 18 U.S.C. 1001.

**ARTICLE 18 – CERTIFICATION REGARDING LOBBYING CERTIFICATION FOR
CONTRACTS, GRANTS, LOANS, AND COOPERATIVE AGREEMENTS**

[Applicable to a subcontract of \$100,000 or more at any tier under a Federal grant.]

Per Contractor's certification given in PART I, Subpart C, Exhibit H, Section G, the language of the following certification shall be included in the award documents for all subcontracts at all tiers and that all subcontractors shall certify and disclose accordingly:

The undersigned certifies, to the best of his or her knowledge and belief, that:

(1) No Federal appropriated funds have been paid or will be paid, by or on behalf of the undersigned, to any person for influencing or attempting to influence an officer or employee of an agency, a Member of Congress, an officer or employee of Congress, or an employee of a Member of Congress in connection with the awarding of any Federal contract, the making of any Federal grant, the making of any Federal loan, the entering into of any cooperative agreement, and the extension, continuation, renewal, amendment, or modification of any Federal contract, grant, loan, or cooperative agreement.

(2) If any funds other than Federal appropriated funds have been paid or will be paid to any person for influencing or attempting to influence an officer or employee of any agency, a Member of Congress, an officer or employee of Congress, or an

employee of a Member of Congress in connection with this Federal contract, grant, loan, or cooperative agreement, the undersigned shall complete and submit Standard Form-LLL, "Disclosure Form to Report Lobbying," in accordance with its instructions.

(3) The undersigned shall require that the language of this certification be included in the award documents for all subawards at all tiers (including subcontracts, subgrants, and contracts under grants, loans, and cooperative agreements) and that all subrecipients shall certify and disclose accordingly.

This certification is a material representation of fact upon which reliance was placed when this transaction was made or entered into. Submission of this certification is a prerequisite for making or entering into this transaction imposed by section 1352, Title 31, U.S. Code. Any person who fails to file the required certification shall be subject to a civil penalty of not less than \$10,000 and not more than \$100,000 for each such failure.

ARTICLE 19 – CLEAN AIR AND WATER CLAUSE / CERTIFICATION

[Applicable to all contracts and subcontracts that exceed \$150,000 --OR-- if facility to be used has been the subject of a conviction under the Clean Air Act (42 U.S.C. 1857c-8(c)(1) or the Federal Water Pollution Control Act (33 U.S.C. 1319(c)) and is listed by EPA --OR-- if the contract/subcontract is not otherwise exempt.]

(a) The Contractor under this contract/subcontract agrees as follows:

(1) To comply with all the requirements of section 114 of the Clean Air Act as amended (42 U.S.C. 1857, et seq., as amended by Public Law 91-604) and section 308 of the Federal Water Pollution Control Act (33 U.S.C. 1251 et seq., as amended by Public Law 92-500), respectively, relating to inspection, monitoring, entry, reports, and information, as well as other requirements specified in section 114 and section 308 of the Air Act and the Water Act, respectively, and all regulations and guidelines issued thereunder before the signing of this contract by the Contracting Local Organization.

(2) That no portion of the work required by this contract will be performed in a facility listed on the Environmental Protection Agency List of Violating Facilities on the date when this contract was signed by the Contracting Local Organization unless and until the EPA eliminates the name of such facility or facilities from such listing.

(3) To use their best efforts to comply with clean air standards and clean water standards at the facilities in which the contract is being performed.

(4) To insert the substance of the provisions of this article in any nonexempt subcontract, including this subparagraph (a)(4).

(b) The terms used in this article have the following meanings:

(1) The term "Air Act" means the Clean Air Act, as amended (42 U.S.C. 1857 et seq., as amended by Public Law 91-604).

(2) The term "Water Act" means Federal Water Pollution Control Act, as amended (33 U.S.C. 1251 et seq., as amended by Public Law 92-55).

(3) The term "clean air standards" means any enforceable rules, regulations, guidelines, standards, limitations, orders, controls, prohibitions, or other requirements which are contained

in, issued under, or otherwise adopted pursuant to the Air Act or Executive Order 11738, an applicable implementation plan as described in section 110(d) of the Clean Air Act (42 U.S.C. 1857c-5(d)), and approved implementation procedure or plan under section 111(c) or section 111(d), respectively, of the Air Act (42 U.S.C. 1857c-6(c) or (d)), or an approved implementation procedure under section 112(d) of the Air Act (42 U.S.C. 1857c-7(d)).

(4) The term "clean water standards" means any enforceable limitation, control, condition, prohibition, standards, or other requirement which is promulgated pursuant to the Water Act or contained in a permit issued to a discharger by the Environmental Protection Agency or by a State under an approved program, as authorized by section 402 of the Water Act (33 U.S.C. 1342), or by a local government to ensure compliance with pretreatment regulations as required by section 307 of the Water Act (3 U.S.C. 1317).

(5) The term "compliance" means compliance with clean air or water standards. Compliance shall also mean compliance with the scheduled or plan ordered or approved by a court of competent jurisdiction, the Environmental Protection Agency or any air or water pollution control issued pursuant thereto.

(6) The term "facility" means any building, plant, installation, structure, mine, vessel or other floating craft, location or site of operations, owned, leased or supervised by a sponsor, to be utilized in the performance of a contract or subcontract. Where a location of site of operations contains or includes more than one building, plant, installation, or structure, the entire location shall be deemed to be a facility except where the Director, Office of Federal Activities, Environmental Protection Agency, determines that independent facilities are collated in one geographical area.

[end of clause]

Per Contractor's certification given in PART I, Subpart C, Exhibit H, Section I, the certification below (and the above Clean Air and Water Clause) shall be included in every nonexempt subcontract and all subcontractors shall certify accordingly:

Clean Air and Water Certification

[Applicable if subcontract exceeds \$150,000 --OR-- if facility to be used has been the subject of a conviction under the Clean Air Act (42 U.S.C. 1857c-8(c)(1) or the Federal Water Pollution Control Act (33 U.S.C. 1319(c)) and is listed by EPA --OR-- if any subcontract is not otherwise exempt.]

Subcontractor certifies as follows:

- (1) Any facility to be utilized in the performance of work described in this subcontract [IS / IS NOT] listed on the Environmental Protection Agency List of Violating Facilities.
- (2) Prior to the signing of a subcontract, to promptly notify the Contracting Local Organization (CLO) under the prime contract of the receipt of any communication from the Director, Office of Federal Activities, U.S. Environmental Protection Agency, indicating that any facility which he/she proposes to use for the performance of the subcontract is under consideration to be listed on the Environmental Protection Agency List of Violating Facilities.

- (3) To include substantially this certification, including this subparagraph (3), in every nonexempt subcontract.

ARTICLE 20 – SUBCONTRACTOR CERTIFICATION (TPDES)

All subcontractors at any tier who perform work that may impact pollution control measures per PART IV, Construction Specification 5 (Pollution Control) must complete and submit, prior to performing any work on the project, a “Subcontractor Certification” form regarding Texas Pollutant Discharge Elimination System (TPDES) permit. This form is included in Appendix A attachment to Construction Specification 5.

NAVARRO COUNTY OFFICE OF PLANNING & DEVELOPMENT

Stanley Young – Director



Osha Joles – Addressing Manager
Scott Wiley – Environmental Services

www.co.navarro.tx.

PLANNING AND ZONING COMMISSION MINUTES

February 2nd, 2017

5:00 P.M.

Item #1. The roll was called and the attendance was as follows:

Chairman Jacobson – present	Vice Chairman Schoppert – present
John Smith - present	Bob McStay – present
Carroll Sigman – absent	Bryan Roach - absent
Vicki Farmer – absent	Jeff Smith - absent
Oliver Jackson – present	Kenneth Guard – present
Kit Herrington - present	Caleb Jackson – present
Julie Humphries – absent	Barbara Moe - absent

Item #2 on the agenda was consideration of the minutes of the December 1st, 2016 Planning and Zoning meeting.
Motion to approve by Commissioner John Smith, second by Commissioner Stuart Schoppert, all voted aye.

Item #3 on the agenda was Planning and Zoning Commissioners re-election of Commissioner Terry Jacobson as the Planning and Zoning Chairman.
Motion to approve by Commissioner John Smith, second by Commissioner Stuart Schoppert, all voted aye. Commissioner Terry Jacobson abstained from voting.

Item #4 on the agenda was Planning and Zoning Commissioners re-election of Stuart Schoppert as the Planning and Zoning Vice-Chairman.
Motion to approve by Chairman Terry Jacobson, second by Commissioner Caleb Jackson, all voted aye. Commissioner Stuart Schoppert abstained from voting.

Item #5 on the agenda was consideration of a re-plat of Plettenberg Bay, Lots 12G and 12H for Walt Stoddard.
Motion to approve by Commissioner Kit Herrington, second by Commissioner Bob McStay, all voted aye.

Item #6 on the agenda was consideration of a re-plat of Hout Bay, Lots 21A and 21B for Mary Mullins. Motion to approve by Commissioner Kit Herrington, second by Commissioner Caleb Jackson, all voted aye.

Item #7 on the agenda was consideration of a re-plat of Arrowhead, Phase 1, combining lots 28, 29 and 30 for Carl Wells. Motion to approve by Vice-chairman Stuart Schoppert, second by Commissioner John Smith, all voted aye. Commissioner Bob McStay abstained from voting.

Item #8 on the agenda was consideration of a re-plat of Francisco Bay, Block 1 combining lots 22 and 23 for Myron and Betty Kimball. Motion to approve by Commissioner Kenneth Guard, second by Commissioner Bob McStay, all voted aye.

Item #9 on the agenda was consideration of a re-plat of The Point combining lots 11, 12 and 13 for David and Cindy Bragg and Richard H. Weed, III. Motion to approve by Commissioner Oliver Jackson, second by Commissioner Kenneth Guard, all voted aye.

Item #10 on the agenda was the Chairman's report. Chairman Jacobson recommended seeking guidance from the City of Corsicana concerning the definition of Shipping Containers used as a habitable structure.

Adjourn.

I, MIKE DOWD, NAVARRO COUNTY TAX ASSESSOR/COLLECTOR, DO HEREBY SWEAR UNDER OATH,
THAT THE ATTACHED REPORT IS A TRUE AND CORRECT REPORT.

TOTAL PAGES INCLUDING COVER SHEET __6__

NAVARRO COUNTY, TEXAS
AD VALOREM TAXES COLLECTED DURING THE MONTH ENDING
MARCH 2017

DESCRIPTION	TAXES	DISCOUNT	PENALTY & INTEREST	SUBTOTAL	COLLECTION FEE	RENTION PENALTY CAD %	NET TAXES DUE	MEMO ONLY ATTY FEES	% CURRENT COLLECTED
NAVARRO COUNTY									
CURRENT	319,430.94		25,491.95	344,922.89		6.86	344,916.03	506.82	18.667,253.70
DELINQUENT	37,839.10		12,447.08	50,286.18		0.29	50,285.89	9,171.83	1.72%
TOTAL	357,270.04		37,939.03	395,209.07		7.15	395,201.92	9,678.65	
NAVARRO COLLEGE									
CURRENT	61,634.23		4,875.15	66,509.38		1.30	66,508.08	97.46	3,608,755.98
DELINQUENT	7,259.47		2,426.35	9,685.82		0.05	9,685.77	1,770.87	1.71%
TOTAL	68,893.70		7,301.50	76,195.20		1.35	76,193.85	1,868.33	
CITY OF RICE									
CURRENT	7,512.48		601.76	8,114.24			8,114.24	29.14	191,909.29
DELINQUENT	1,533.87		12.60	1,546.47			1,546.47	10.57	3.91%
TOTAL	9,046.35		614.36	9,660.71		0	9,660.71	39.71	
CITY OF KERENS									
CURRENT	8,810.33		641.42	9,451.75		0.24	9,451.51	13.45	280,641.20
DELINQUENT	1,431.35		698.52	2,129.87			2,129.87	425.96	3.14%
TOTAL	10,241.68		1,339.94	11,581.62		0.24	11,581.38	439.41	
CITY OF CORSICANA									
CURRENT	105,182.15		8,338.62	113,520.77		6.39	113,514.38	225.49	8,184,763.77
DELINQUENT	13,938.78		4,700.12	18,638.90		0.30	18,638.60	3,370.39	1.29%
TOTAL	119,120.93		13,038.74	132,159.67		6.69	132,152.98	3,595.88	

TOTAL TAX REPORT
PREPARED BY JACKIE OWEN
NAVARRO COUNTY TAX

NAVARRO COUNTY, TEXAS
AD VALOREM TAXES COLLECTED DURING THE MONTH ENDING
MARCH 2017

DESCRIPTION	TAXES	DISCOUNT	PENALTY & INTEREST	SUBTOTAL	COLLECTION FEE	RENTITION PENALTY	NET TAXES DUE	MEMO ONLY ATTY FEES	% CURRENT COLLECTED
CITY OF BARRY									
CURRENT	109.02			109.02			109.02		19,409.20
DELINQUENT	60.52		22.15	82.67			82.67	16.53	0.56%
TOTAL	169.54	-	22.15	191.69	-	0	191.69	16.53	
CITY OF EMHOUSE									
CURRENT	261.80	-	21.81	283.61			283.61		9,340.73
DELINQUENT	269.62		210.86	480.48			480.48	61.58	2.80%
TOTAL	531.42	-	232.67	764.09	-	0	764.09	61.58	
CITY OF RICHLAND									
CURRENT	966.18	-	86.94	1,053.12			1,053.12		19,709.75
DELINQUENT									4.90%
TOTAL	966.18	-	86.94	1,053.12	-	0	1,053.12		
CITY OF GOODFLOW									
CURRENT	145.18	-	12.00	157.18			157.18		3,905.37
DELINQUENT	143.90		75.62	219.52			219.52	42.18	%
TOTAL	289.08	-	87.62	376.70	-	0	376.70	42.18	3.72%
CITY OF FROST									
CURRENT	1,621.58		128.38	1,749.96			1,749.96		85,425.98
DELINQUENT	76.02		19.78	95.80			95.80	19.17	1.90%
TOTAL	1,697.60	-	148.16	1,845.76	-	0.00	1,845.76	19.17	
CITY OF DAWSON									
CURRENT	2,583.06		204.80	2,787.86			2,787.86	17.36	87,969.77
DELINQUENT	227.14		61.57	288.71			288.71	57.73	2.94%
TOTAL	2,810.20	-	266.37	3,076.57	-	0	3,076.57	75.09	

TOTAL TAX REPORT
PREPARED BY JACKIE OWEN
NAVARRO COUNTY TAX

NAVARRO COUNTY, TEXAS
AD VALOREM TAXES COLLECTED DURING THE MONTH ENDING
MARCH 2017

DESCRIPTION	TAXES	DISCOUNT	PENALTY & INTEREST	SUBTOTAL	COLLECTION FEE	RENTITION PENALTY	NET TAXES DUE	MEMO ONLY ATTY FEES	% CURRENT COLLECTED
CITY-BLOOMING GROVE									
CURRENT	766.71		58.83	825.54			825.54		LEVY 110,732.31
DELINQUENT									0.69%
TOTAL	766.71	-	58.83	825.54	-	0.00	825.54	-	
NAVARRO COUNTY ESD #1									LEVY
CURRENT	3,229.05		238.42	3,467.47	108.26	0.02	3,359.19	0.98	143,356.33
DELINQUENT	282.53		124.27	406.80			406.80	81.38	2.25%
TOTAL	3,511.58	-	362.69	3,874.27	108.26	0.02	3,765.99	82.36	
BLOOMING GROVE ISD									LEVY
CURRENT	33,529.56		2,677.38	36,206.94			36,206.94		1,887,232.41
DELINQUENT	7,413.46		2,104.49	9,517.95			9,517.95	1,903.55	1.78%
TOTAL	40,943.02	-	4,781.87	45,724.89	-	0	45,724.89	1,903.55	
DAWSON ISD									LEVY
CURRENT	34,778.61		2,955.83	37,734.44			37,734.44	48.21	1,932,022.90
DELINQUENT	3,122.29		1,084.85	4,207.14			4,207.14	841.41	1.80%
TOTAL	37,900.90	-	4,040.68	41,941.58	-	0	41,941.58	889.62	
RICE ISD									LEVY
CURRENT	40,966.01		3,451.53	44,417.54			44,417.54	104.73	1,523,149.11
DELINQUENT	8,653.49		1,250.48	9,903.97			9,903.97	645.33	2.69%
TOTAL	49,619.50	-	4,702.01	54,321.51	-	0.00	54,321.51	750.06	

NAVARRO COUNTY, TEXAS
AD VALOREM TAXES COLLECTED DURING THE MONTH ENDING
MARCH 2017

DESCRIPTION	TAXES	DISCOUNT	PENALTY & INTEREST	SUBTOTAL	COLLECTION FEE	RENTION PENALTY	NET TAXES DUE	MEMO ONLY ATTY FEES	% CURRENT COLLECTED
CORSICANA ISD									LEVY
CURRENT	256,799.25		21,384.04	278,183.29		14.10	278,169.19	574.42	20,164,556.40
DELINQUENT	30,199.59		10,101.84	40,301.43		0.61	40,300.82	7,577.23	1.27%
TOTAL	286,998.84		31,485.88	318,484.72		14.71	318,470.01	8,151.65	
FROST ISD									LEVY
CURRENT	13,994.50		1,202.87	15,197.37			15,197.37		1,148,603.71
DELINQUENT	2,782.65		1,065.37	3,848.02			3,848.02	769.63	1.22%
TOTAL	16,777.15		2,268.24	19,045.39			19,045.39	769.63	
KERENS ISD ^									LEVY
CURRENT	62,533.35		4,645.27	67,178.62		0.39	67,178.23	21.83	2,845,425.69
DELINQUENT	3,080.60		1,242.45	4,323.05			4,323.05	864.63	2.20%
TOTAL	65,613.95		5,887.72	71,501.67		0.39	71,501.28	886.46	
OLD ROADS									LEVY
CURRENT									
DELINQUENT									
TOTAL									
MILDRED ISD									LEVY
CURRENT	95,269.84		7,325.91	102,595.75			102,595.75	317.54	5,101,840.75
DELINQUENT	7,596.00		2,380.29	9,976.29			9,976.29	1,995.75	1.87%
TOTAL	102,865.84		9,706.20	112,572.04			112,572.04	2,313.29	
GRAND TOTAL	1,176,934.21		124,371.60	1,300,405.81	108.26	30.55	1,300,267.00	31,583.15	

YR-TO-DATE % CURRENT COLLECTED:

COUNTY	93.45%	CITY - FROST	87.57%
COLLEGE	93.30%	CITY DAWSON	88.36%
RICE	92.81%	CITY-BL GROVE	92.10%
KERENS	88.01%	NC ESD #1	92.79%
CORSICANA	94.28%	B G ISD	92.57%
BARRY	87.61%	DAWSON ISD	93.21%
EMHOUSE	85.11%	RICE ISD	93.01%
RICHLAND	89.87%	CORSICANA ISD	94.52%
GOODLOW	75.30%	FROST ISD	93.40%
		KERENS ISD	93.44%
		MILDRED ISD	93.57%

TOTAL TAX REPORT
PREPARED BY JACKIE OWEN
NAVARRO COUNTY TAX

NAVARRO COUNTY, TEXAS
AD VALOREM TAXES COLLECTED DURING THE MONTH OF
MARCH 2017

CURRENT TAXES	TAXES	PENALTY & INTEREST	SUBTOTAL	RENDITION PENALTY CAD %	NET TAXES DUE	MEMO ONLY ATTORNEY FEES
COUNTY	260,667.26	20,781.47	281,448.73	5.60	281,443.13	413.06
ROAD & BRIDGE	54,243.11	4,349.29	58,592.40	1.17	58,591.23	86.48
FLOOD CONTROL	4,520.57	361.19	4,881.76	0.09	4,881.67	7.28
TOTAL	319,430.94	25,491.95	344,922.89	6.86	344,916.03	506.82
DELINQUENT TAXES						
COUNTY	30,862.62	10,164.90	41,027.52	0.24	41,027.28	7,483.86
STATE						
ROAD & BRIDGE	6,447.11	2,108.72	8,555.83	0.05	8,555.78	1,559.72
FLOOD CONTROL	529.37	173.46	702.83	-	702.83	128.25
TOTAL	37,839.10	12,447.08	50,286.18	0.29	50,285.89	9,171.83
TOTAL ALLOCATION						
COUNTY	291,529.88	30,946.37	322,476.25	5.84	322,470.41	7,896.92
STATE		-		-		
ROAD & BRIDGE	60,690.22	6,458.01	67,148.23	1.22	67,147.01	1,646.20
FLOOD CONTROL	5,049.94	534.65	5,584.59	0.09	5,584.50	135.53
TOTAL	357,270.04	37,939.03	395,209.07	7.15	395,201.92	9,678.65

220



TEXAS FOOD SERVICE EQUIPMENT CO.

P.O. Box 1449
Manvel, Texas 77578-1449
E-Mail: david@texasfoodservice.com

(713) 926-7300
Fax (713) 926-9300
Toll Free (877) 282-3637

BUDGET QUOTE
NAVARRO COUNTY JAIL
312 West 2 nd St.
Corsicana, Texas 75110

903-654-3012
Capitan Charlie York

Insinger Tray Washer Model TRAC Tray Washer 321-2
High Temp / 528 Trays per hour
Electric Booster Heater
Security Package

Tray Dryer Model TD 321-3
Tray Unload Table

Factory Basic Install
Exhaust Venting by others

Sure Fire Start-Up & Check out service
Direction of flow to be stated later

Basic unit price.....	22,500.00
Booster Heater.....	3,500.00
Security Package.....	4,000.00
Recpt. Table.....	3,100.00
Tray Dryer.....	9,800.00
Factory Install.....	2,000.00
Freight.....	600.00
 Your Total Price.....	 \$ 45,500.00



TEXAS FOOD SERVICE EQUIPMENT CO.

www.texasfoodservice.com

POLAR KING OUTDOOR COOLERS/FREEZERS
INSINGER DISH/TRAY MACHINES

David Roessler, Sr.

P.O. Box 1449
Manvel, Texas 77578-1449
david@texasfoodservice.com

Direct 713.906.0662
Office 713.926.7300
Toll Free 877.282.3637

TRAC 321-2

Automatic Single Tank Tray Washer

- Automatic conveyor, single tank tray washer with recirculating wash and fresh water final rinse.
- 248 gallons/hour final rinse consumption
- Capacity is 528 trays per hour (based on a 15" tray)

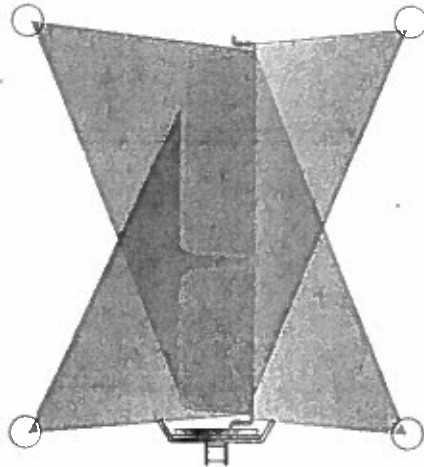
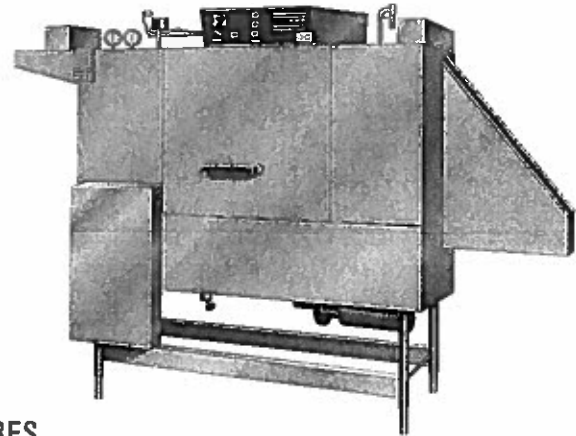

Insinger's traywashers were developed specifically to optimally clean and sanitize ware by reaching all corners and crevices with a vertical spray.

STANDARD FEATURES

- Tank heat: 15 kW electric immersion heater or steam injector
- Capillary thermometers for wash and rinse
- In-line thermometer for final rinse
- Vacuum breaker on all incoming water lines
- Manifold clean-out brush
- Vents with adjustable damper controls
- SureFire® Start-Up & Check-Out Service
- Single point electrical connection: motor, controls and tank heat (Booster requires a separate connection)
- Inspection door
- S/S frame, legs and feet
- S/S front enclosure panel
- Automatic tank fill
- Low water protection
- Detergent connection provision
- Top mounted NEMA 12 control panel
- Simplified scrap screen design
- Door safety switch
- Standard frame drip proof motors
- Override switch for de-liming
- End caps/pipe plugs secured to prevent loss
- Tray unload table

TRAC 321-2

OPTIONS

- Stainless steel steam coil tank heat
- Steam booster
- Electric booster
- Pressure reduction valve and line strainer
- Security package
- Insulated hood and door
- Chemical sanitizer injector package for low temperature operations (pump by others)
- Tray Dryer
- Tray Stacker

AUTOQUOTES





559

TRAC 321-2

Automatic Single Tank Tray Washer

Capacity Per Hour	528 trays
Tank Capacity	24.1 gallons
Motor Size	2 hp (wash) 1/15 hp (conveyor)
Electric Usage	15 kW wash tank 27 kW booster 40° rise 45 kW booster 70° rise
Steam Consumption at 20 psi min.	54 lbs./hour tank
Final Rinse Peak Flow at 20 psi min.	4.1 gallons/minute
Final Rinse Consumption at 20 psi min.	248 gallons/hour
Exhaust Hood Requirement	100 CFM Load 300 CFM unload
Peak Rate Drain Flow	9 gallons/minute
Shipping Weight	700 lbs.

Machine Electrical*		
Motors, Controls, Tank Heat	Steam	Electric without booster
208/3/60	8.5	50.1
240/1/60	N/A	N/A
240/3/60	7.8	43.9
480/3/60	3.9	21.9
380/3/50	4.7	27.5

*Booster heater wired separately. Machine load only listed above.

SPECIFICATIONS

CONSTRUCTION- Hood and tank constructed of 16 gauge type 304 S/S. Hood unit of all welded seamless construction. S/S frame, legs and feet. All internal castings are non-corrosive lead free nickel alloy, bronze or S/S.

DOORS- Extra large die formed 18-8 type 304 S/S front inspection door riding in all S/S channels. A triple ply leading edge on the door channels made of S/S with no plastic or nylon sleeves or liners used. Two intermediate S/S door-safety stops on the door.

CONVEYORS- One S/S roller conveyor chain with tray cradles. Width between guide rails is factory-adjustable from 1.5" to 3.7". Conveyor accommodates trays up to 15" high. Conveyor drive system includes direct drive gear motor with frictionless, trouble-free overload release system continuously running. Trays conveyed automatically through washing and rinsing systems powered by independent conveyor motor.

PUMP- Centrifugal type "packless" pump with a brass petcock drains. Construction includes ceramic seal and a balanced cast impeller on a precision ground stainless steel shaft, extension or sleeve. All working parts mounted as an assembly and removable as a unit without disturbing pump housing. 2 hp wash motor standard horizontal C-face frame, drip proof, internally cooled with ball-bearing construction.

CONTROLS- Top mounted control cabinet, NEMA 12 rated with heat insulation provided between hood and control cabinet, housing motor controls and overload protection, transformer, contactors and all dishwasher integral controls. All controls safe low voltage 24 VAC.

ENERGY SAVER- Electric photo-eye automatically operates the final rinse solenoid only when a tray passes, saving water and energy. The eye also activates an adjustable timer control. If no tray passes during the set time, the machine shuts down.

SPRAY SYSTEM- Wash and final rinse spray systems are made of 18-8 type 304 stainless steel pipe. Wash assemblies removable without the use of tools.

WASH- Four wash arms threaded into S/S manifold. (2 on each side of conveyor). Each pipe designed with 8 high pressure action cleansing slots. The slots are precision milled for water control producing a fan spray.

FINAL RINSE- Eight nozzle assemblies on either side of conveyor threaded into S/S pipes. Nozzle assemblies produce a fan spray reducing water consumption, maximizing heat retention.

DRAIN- Drain valve externally controlled. Overflow assembly with skimmer cap is removable without the use of tools for drain line inspection. Heater is protected by low water level control.

UNLOAD TABLE- a stainless steel tray unload table receives clean trays. Table constructed with guide rails which ease the trays onto table.

Note: Due to product improvement we reserve the right to change information and specifications without notice.

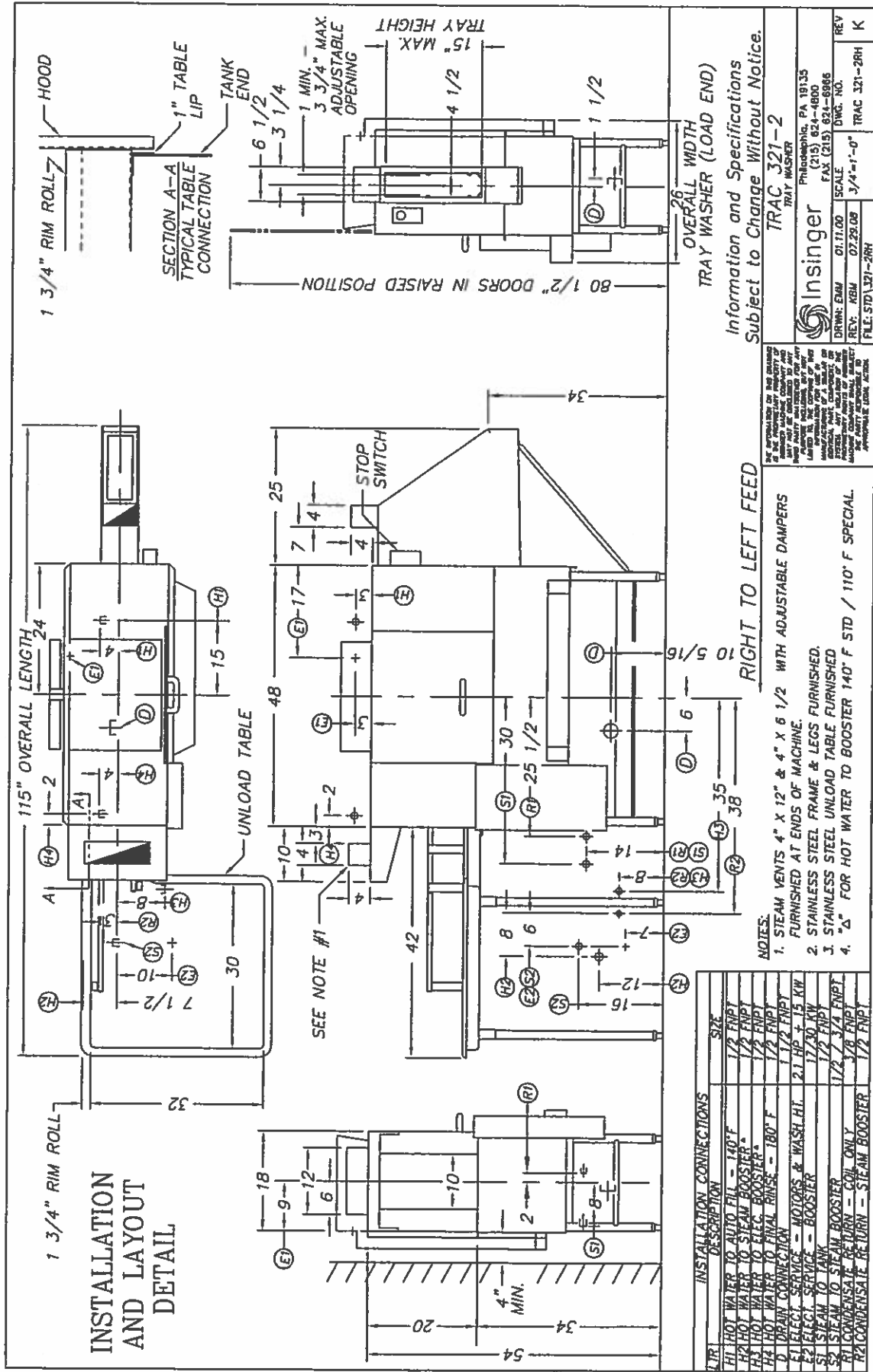

Information and Specifications
Subject to Change Without Notice.

TRAC 321-2
TRAY WASHER

Philadelphia, PA 19135
(215) 624-4800
FAX (215) 624-6966

DRWN: EMJ
REV: KEM
SCALE
01.11.00
07.29.08
3/4"-1"-0"

REV
K

RIGHT TO LEFT FEED

OVERALL WIDTH
TRAY WASHER (LOAD END)

26

80 1/2" DOORS IN RAISED POSITION

15" MAX. TRAY HEIGHT

4 1/2

1 1/2

6 1/2

3 1/4

1 MIN. - 3 3/4" MAX. ADJUSTABLE OPENING

SECTION A-A
TYPICAL TABLE CONNECTION

1" TABLE LIP

TANK END

HOOD

1 3/4" RIM ROLL

115" OVERALL LENGTH

UNLOAD TABLE

STOP SWITCH

SEE NOTE #1

42

34

10 5/16

6

35

38

30

25 1/2

25

7

4

4

17

48

15

15

24

2

32

7 1/2

10

10

12

16

14

8

6

7

18

9

12

6

10

2

8

4" MIN.

20

34

54

1 3/4" RIM ROLL

NOTES:

1. STEAM VENTS 4" X 12" & 4" X 6 1/2" WITH ADJUSTABLE DAMPERS FURNISHED AT ENDS OF MACHINE.
2. STAINLESS STEEL FRAME & LEGS FURNISHED.
3. STAINLESS STEEL UNLOAD TABLE FURNISHED.
4. "Δ" FOR HOT WATER TO BOOSTER 140° F STD / 110° F SPECIAL.

TYPE	DESCRIPTION	SIZE
H1	HOT WATER TO AUTO FILL - 140° F	1/2 FNPT
H2	HOT WATER TO STEAM BOOSTER*	1/2 FNPT
H3	HOT WATER TO ELEC. BOOSTER*	1/2 FNPT
H4	HOT WATER TO FINAL RINSE - 180° F	1/2 FNPT
D	DRAIN CONNECTION	1 1/2" NPT
E1	ELECT. SERVICE - MOTORS & WASH. HT.	2.1 WBS + 15 KW
E2	ELECT. SERVICE - BOOSTER	1/2 WBS
S1	STEAM TO STEAM BOOSTER	1/2 FNPT
S2	STEAM TO STEAM BOOSTER	1/2 FNPT
R1	CONDENSATE RETURN - COIL ONLY	3/8 FNPT
R2	CONDENSATE RETURN - STEAM BOOSTER	1/2 FNPT

Contact Insinger Sales at 800-344-4802 for an Installation Drawing Specific to Your Application
This drawing is available on the Insinger Web site at www.insingermachine.com

TRAC 321-2

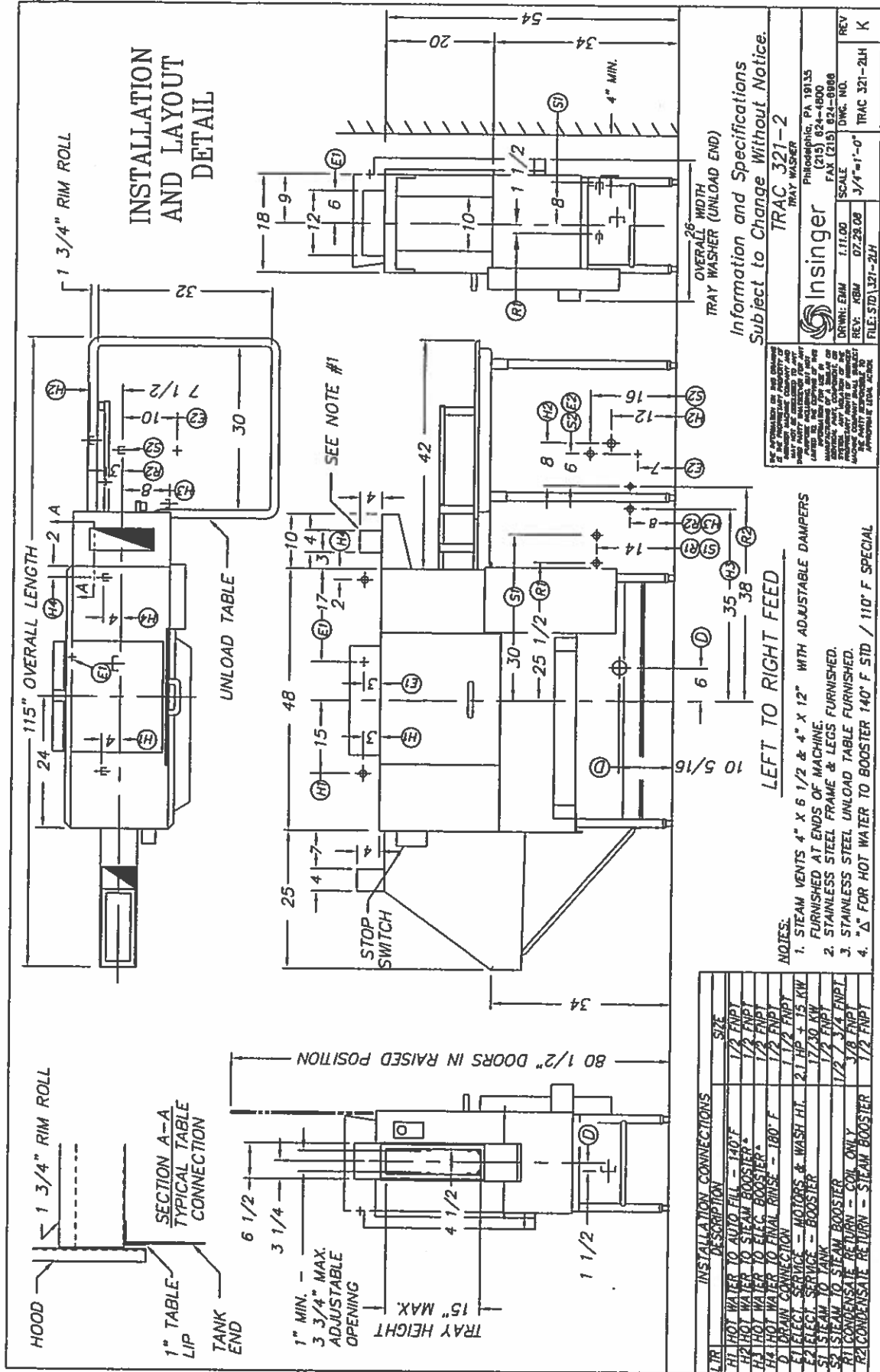

LINE	INSTALLATION CONNECTIONS DESCRIPTION	SIZE
H1	HOT WATER TO AUTO FIL	1/2" FNPT
H2	HOT WATER TO STEAM BOOSTER*	1/2" FNPT
H3	HOT WATER TO ELEC. BOOSTER*	1/2" FNPT
H4	HOT WATER TO FINAL RINSE - 180° F	1/2" FNPT
D	DRAIN CONNECTION	1/2" FNPT
E1	ELECT. STRUCK - MOTORS & WASH HI.	2.1 HP - 15 KW
E2	ELECT. STRUCK - BOOSTER	17/30 KW
S1	STEAM TO TANK	1/2" FNPT
S2	STEAM TO STEAM BOOSTER	1/2" FNPT
R1	CONDENSATE RETURN - COIL ONLY	3/8" FNPT
R2	CONDENSATE RETURN - STEAM BOOSTER	1/2" FNPT

- NOTES:
1. STEAM VENTS 4" X 6 1/2" & 4" X 12" WITH ADJUSTABLE DAMPERS FURNISHED AT ENDS OF MACHINE.
 2. STAINLESS STEEL FRAME & LEGS FURNISHED.
 3. STAINLESS STEEL UNLOAD TABLE FURNISHED.
 4. * Δ FOR HOT WATER TO BOOSTER 140° F STD / 110° F SPECIAL

Contact Insinger Sales at 800-344-4802 for an Installation Drawing Specific to Your Application
 This drawing is available on the Insinger Web site at www.insingermachine.com

TD-321-3

Automatic Tray Dryer (Optional Component)

- ▣ Automatic conveyor tray dryer provides 99% dry trays
- ▣ Unique Air Wiper design reduces ability for bacteria to grow on wet, stacked trays
- ▣ Drier and cleaner workplace—less racking of trays for drying
- ▣ Increased productivity
- ▣ Capacity is compatible with the tray washer and based on a 15" tray
- ▣ Designed for left or right hand conveyor travel, as specified.
- ▣ Furnished only as an added component to a TRAC 321-2, TRAC 321-2 RPW or TRAC 878 traywasher

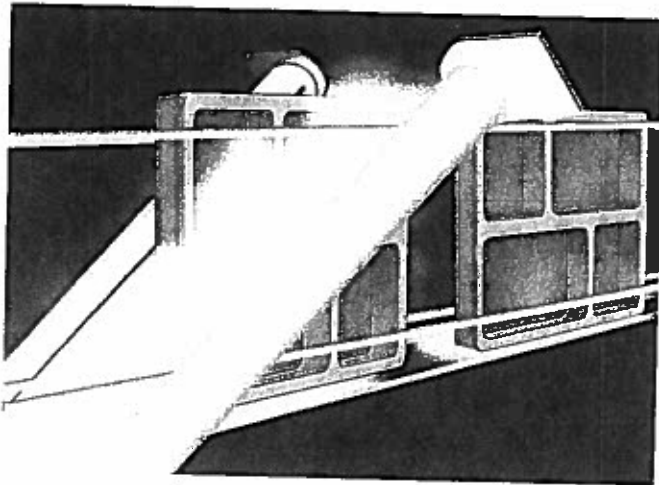
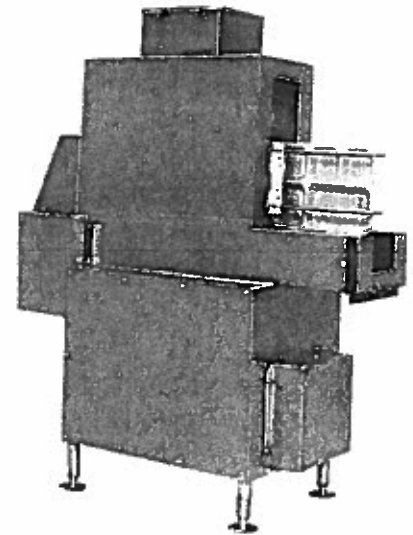

Insinger's unique Air Wiper design leaves trays 99% dry saves labor and provides a cleaner drier workplace.

STANDARD FEATURES

- ▣ Stainless steel frame, legs and feet
- ▣ Top mounted NEMA 12 control panel
- ▣ SureFire® Start-Up & Check-Out Service

OPTIONS

- Security package
- Tray Stacker

TD321-3

AUTO



Intertek



Capacity Per Hour	Compatible with the tray washer and based on a 15" tray	
Motor Size	10 hp (blower) 1/15 hp (conveyor)	
Shipping Weight	700 lbs.	
Additional Current Draw Amps when Connected to Tray Washer	Electric Customer Fuse	
208/3/60	31.0	FRN-R-60
240/3/60	28.2	FRN-R-60
380/3/50	17.0	FRS-R-35
480/3/60	14.1	FRS-R-30

SPECIFICATIONS

CONSTRUCTION- Hood and tank constructed of 16 gauge 18-8 type 304 S/S. Hood unit of all welded seamless construction. S/S frame, legs and feet.

CONVEYOR- One stainless steel roller conveyor chain with tray cradles, through both washer and dryer. Width between guide rails is factory adjustable from 1.5" to 3.7". Conveyor accommodates trays up to 15" high. Conveyor drive system includes direct drive gear motor with frictionless, trouble-free overload release system continuously running.

CONTROLS- Top-mounted control cabinet, NEMA 12 rated, housing motor controls and overload protection, transformer and contactors. All controls safe low voltage 24 VAC.

BLOWER- 10 hp regenerative blower with Insinger's specially designed "air wiper" mounted on either side of conveyor. "Air wipers" are mounted on a diagonal to sweep water in controlled movement preventing splashing and uneven results.

DRAIN- All water is drained back into TRAC 321-2, TRAC 321-2 RPW or TRAC 878 with gravity drain connection. Factory installed drain connection to tray washer provided if dryer is ordered with a TRAC 321-2, TRAC 321-2 RPW or TRAC 878.

UNLOAD TABLE- A stainless steel tray unload table receives clean trays. Table constructed with guide rails which ease the trays onto table.

Note: Due to product improvement we reserve the right to change information and specifications without notice.

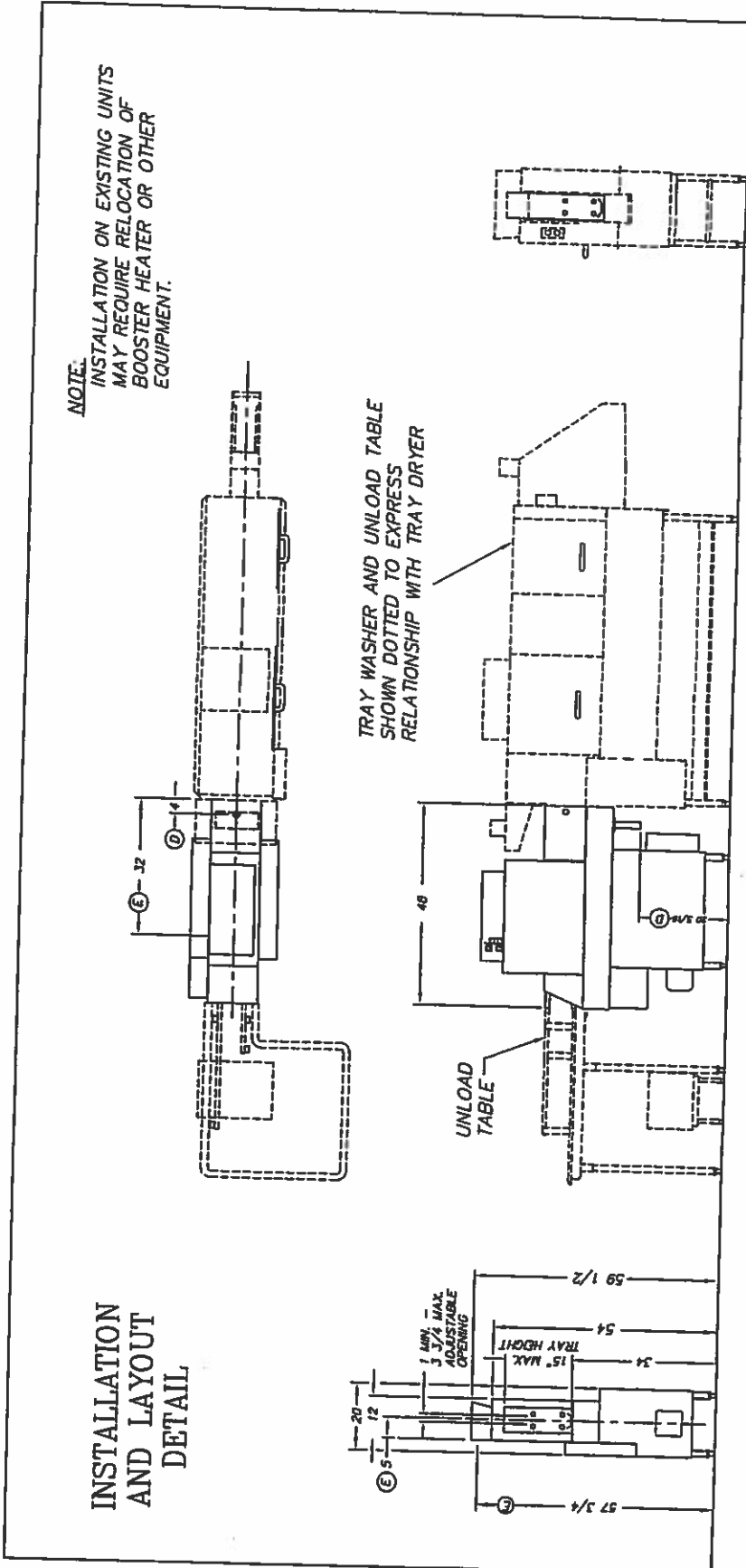

NOTE:
INSTALLATION ON EXISTING UNITS
MAY REQUIRE RELOCATION OF
BOOSTER HEATER OR OTHER
EQUIPMENT.

TRAY WASHER AND UNLOAD TABLE
SHOWN DOTTED TO EXPRESS
RELATIONSHIP WITH TRAY DRYER

RIGHT TO LEFT FEED

NOTE: HOOK UP KIT FOR CONNECTION TO INSINGER
TRAY WASHER AVAILABLE, DWG. # 1361-105.

TRAY DRYER
UNLOAD END SHOWN

Information and Specifications
Subject to Change Without Notice.
TD 321-3 TRAY DRYER
SINGLE TANK CONVEYER TYPE DRAINING MACHINE
Philadelphia, PA 19135
824-4800
INSINGER
SCALE 1/2" = 1'
REV. AEM 01.17.00 DWG. NO. TD321-3R
REV. KEM 02.29.08
FILE: STD TD321-3R

ELECTRICAL CHARACTERISTICS	
VOLTAGE	AMPS
208	31
230	28.2
460	14.1
380	17
CUSTOMER FUSE	
FRN-R-60	
FRN-R-60	
FRS-R-30	
FRS-R-35	

INSTALLATION CONNECTIONS	
LTR	DESCRIPTION
E	ELECT. SERVICE - BLOWER MTR.
D	DRAIN
	SIZE
	10 HP
	1 1/2 O.D. TUBE

Contact Insinger Sales at 800-344-4802 for an Installation Drawing Specific to Your Application
This drawing is available on the Insinger Web site at www.insingermachine.com

TD 321-3



February 24, 2017

Judge HM Davenport
 Navarro County
 300 West 3rd Avenue
 Corsicana, TX 75110
 903.654.3025 (Office)
hdavenport@navarrocounty.org

Re: Navarro County Courthouse Repairs

Phoenix I Restoration and Construction is pleased to offer you this proposal to provide all necessary labor, material, and supervision to perform the following scope of work:

Scope:

Additional cutting and pointing at fourth floor.

Project Cost:

Description	Qty	Unit	Unit Price	Subtotal
Labor	370	hrs	\$ 52.00	\$ 19,240.00
Misc. Material	1	ls	\$ 964.00	\$ 964.00
Lift Rental	1	ls	\$ 4,364.00	\$ 4,364.00
Subtotal				\$ 24,568.00
Markup	15	%		\$ 3,685.20
Project Total				\$ 28,253.20

Phoenix I Restoration and Construction, Ltd.
 14032 Distribution Way, Farmer's Branch, TX 75234 ● 214-902-0111 ● 214-904-9635 (Fax)

Thank you for the opportunity to bid this project. If you have any questions about this proposal, please feel free to call our office at 214-902-0111.

Respectfully,

Dale Sellers
President/CEO of General Partner

Please sign and date below to accept this proposal:

 4-10-17